

Series 6PF Positioning Feedback cylinders

Double-acting low friction, magnetic
 ø 50, 63, 80, 100, 125 mm



Series 6PF pneumatic actuators are equipped with a potentiometric linear position transducer integrated inside the rod. This type of cylinder allows, along the entire stroke, a constant control of the rod position which is read processing the change of the transducer internal resistance.

The pistons have been equipped with a permanent magnet which enables the use of external end-stroke sensors. The dynamic seals are specific for low friction.

Thanks to the electrical connection, realized by means of an M12 male electric round connector positioned on the rear head, these cylinders fulfil the standards of IP67 protection class.

Series 6PF cylinders comply with the ISO 15552 standards and can be assembled with the entire range of standard accessories. They are available with bores from 50mm to 125mm with standard strokes from 50mm to 500mm with intervals of 50mm.

The sturdy design, the flexible installation and the high performance make Series 6PF suitable for use in applications with tensioning cylinders, positioning cylinders and filling, cutting and measuring systems.

- » In compliance with ISO 15552 standards and with the previous DIN/ISO 6431 - VDMA 24562 standards
- » Chrome plated steel rod
- » Protection class IP67
- » Minimal sliding speed of 5 mm/sec
- » Minimal sliding pressure < 0,1 bar
- » G variant for dusty applications (cement, resin, mud, residues from wood, etc...)
- » ATEX version available

GENERAL AND TECHNICAL DATA

PNEUMATIC SECTION	
Construction	inner tie-rods
Operation	double-acting low friction, not cushioned
Materials	see the table on the following page
Mountings	front and rear flange foot mounts front / rear / swivel / intermediate trunnion
Bores	50, 63, 80, 100, 125 mm
Strokes (min - max)	50 ÷ 1000 mm (step 50 mm)
Operating Temperature	0°C ÷ 80°C (with dry air -20°C)
Operating pressure	0.1 ÷ 10 bar
Speed (min - max)	5 ÷ 1000 mm/sec (no load)
Max acceleration	10 m/sec ²
Media	filtered air class 5.4.4 according to ISO 8573-1. If lubricated air is used, it is recommended to use oil ISOVG32. Once applied the lubrication should never be interrupted.
Linearity	0.1% of the stroke
Repeatability	0.03% of the stroke
Resolution	Infinite
Hysteresis	< di 0.5 mm
Vibration test according EN 60068-2-6	severity level 3
Shock test according EN 60068-2-27	severity level 2
ELECTRICAL SECTION	
Electrical connection	male connector M12 4 poles IP 67 (EN 60529)
Max input voltage	40 V (stroke 50 mm) 60 V (strokes from 100 to 500 mm)
Max recommended cursor current	< di 0,1 µA
Electrical resistance	5 kohm for strokes from 50 to 300 mm 10 kohm for strokes from 350 to 500 m
Tolerance on resistance	+/- 20%
Max dissipation (40°C)	1 W for stroke 50 mm 2 W for stroke 100 mm 3 W for strokes from 150 to 500 mm
Suitable end-stroke sensors	CST-532 (3 wires) CST-562 (M8)
Suitable M12 connectors	CS-LF04HB (straight female connector 4 poles) CS-LR04HB (right angle female connector 4 poles) CS-LF05HB-D200 (straight female wired connector 5 poles, 2 meters) ** CS-LF05HB-D500 (straight female wired connector 5 poles, 5 meters) ** CS-LR05HB-D200 (right angle female wired connector 5 poles, 2 meters) ** CS-LR05HB-D500 (right angle female wired connector 5 poles, 5 meters) **
** pin No 5 must not be connected	

STANDARD STROKES FOR SERIES 6PF CYLINDERS

✕ = Double-acting, low friction

STANDARD STROKES																					
∅	50	100	150	200	250	300	350	400	450	500	550	600	650	700	750	800	850	900	950	1000	
50	✕	✕	✕	✕	✕	✕	✕	✕	✕	✕	✕	✕	✕	✕	✕	✕	✕	✕	✕	✕	✕
63	✕	✕	✕	✕	✕	✕	✕	✕	✕	✕	✕	✕	✕	✕	✕	✕	✕	✕	✕	✕	✕
80	✕	✕	✕	✕	✕	✕	✕	✕	✕	✕	✕	✕	✕	✕	✕	✕	✕	✕	✕	✕	✕
100	✕	✕	✕	✕	✕	✕	✕	✕	✕	✕	✕	✕	✕	✕	✕	✕	✕	✕	✕	✕	✕
125	✕	✕	✕	✕	✕	✕	✕	✕	✕	✕	✕	✕	✕	✕	✕	✕	✕	✕	✕	✕	✕

CODING EXAMPLE

6PF	3	P	050	A	0200
6PF	SERIES				
3	OPERATION: 3 = double-acting low friction, no cushion			PNEUMATIC SYMBOLS CD22	
P	MATERIALS: P = see the table on the following page				
050	BORES: 050 = 50 mm 063 = 63 mm 080 = 80 mm 100 = 100 mm 125 = 125 mm				
A	CONSTRUCTION: A = standard with rod nut RL = cylinder with rod lock				
0200	STROKES (see the table)				
VERSIONS: = standard P = PU rod seal V = FKM rod seal L = without rod seal (rear supply only) * G = with brass rod scraper EX = ATEX (___) = extended piston rod ___ mm * The possibility to order the cylinder without piston rod seal further reduces the friction force.					

PNEUMATIC SYMBOLS

The pneumatic symbols which have been indicated in the CODING EXAMPLE are shown below.

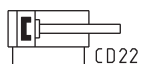

GENERAL INFORMATION

To function properly, the potentiometer must be used as a voltage divider and not as a variable resistor.

The measurement must be carried out detecting the voltage and not the resistance.

The electrical connection must be done at an high impedance inlet.

Information about pinout can be found in the instruction sheet or on the product itself.

NOTE TO THE CONNECTOR DRAWING:
1, 3 = inlet voltage
4 = outlet signal
2 = not used

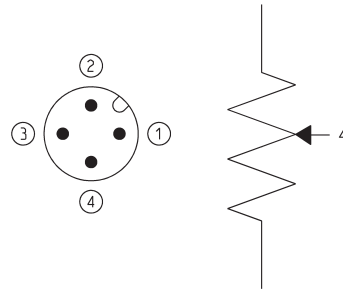
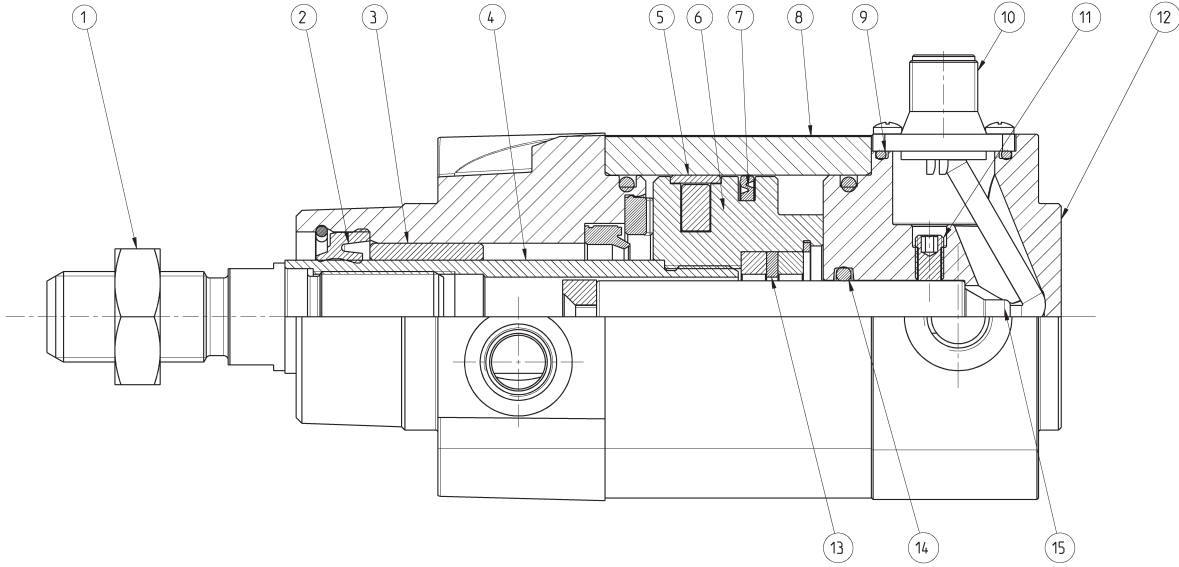

LIST OF COMPONENTS	
PARTS	MATERIALS
1. Rod nut	Steel
2. Rod seal	NBR
3. Rod guide bush	Sintered bronze
4. Rod	Chrome plated steel
5. Piston guide element	Acetal resin
6. Piston	Aluminium
7. Piston seal	NBR
8. Extrusion profile	Anodized aluminium
9. OR seal	NBR
10. M12 connector	Nickel plated brass
11. Grain	Steel
12. Rear endcap	Aluminium
13. Magnetic actuator	Neodymium
14. OR seal	NBR
15. Positioning sensor	-

CYLINDERS ACCESSORIES SERIES 6PF



Piston rod socket joint
Mod. GY



Piston rod lock nut
Mod. U



Clevis pin Mod. S

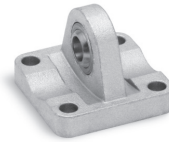

Rear trunnion ball-joint
Mod. R

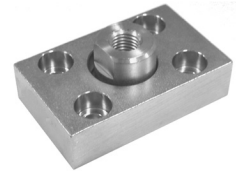

Coupling piece
Mod. GKF



Swivel ball joint Mod. GA

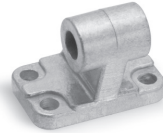

90° male trunnion
Mod. ZC

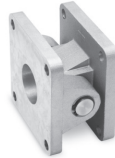

Swivel Combination
Mod. C+L+S

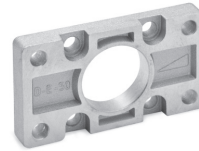

Front and rear flange
Mod. D-E



Self aligning rod
Mod. GK



Centre trunnion Mod. F



Foot mount Mod. B

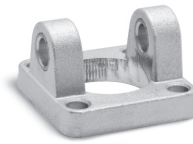

Front female trunnion
Mod. H and C-H

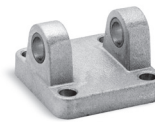

Rear female trunnion
Mod. C and C-H

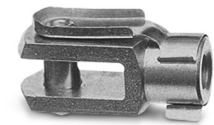

Rod fork end Mod. G

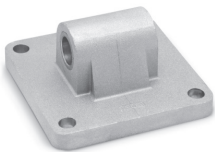

Rear trunnion male Mod. L



Key to disassemble
cylinders Ø 80 and 100



Counter bracket for centre
trunnion Mod. BF



Straight conn. for power
supply Mod. CS-LF04HB



Angular conn. for power
supply Mod. CS-LR04HB



Cable
Mod. CS-LF05HB-D...



Cable
Mod. CS-LR05HB-D...



All accessories are supplied separately, except for piston rod lock nut Mod. U

Series 6PF cylinders



+ = add the stroke

Table note:
* = special key 80-62/8C
(see accessories)

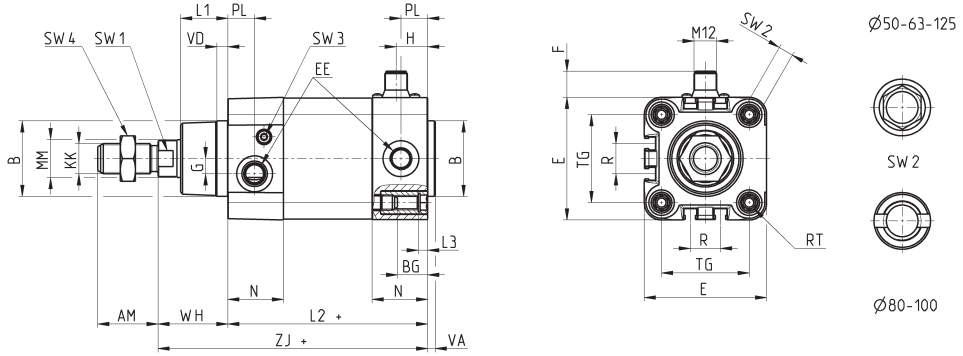

DIMENSIONS																										
Ø	AM	B	BG	E	EE	F	G	H	KK	L1	L2+	L3	MM	N	PL	R	RT	SW1	SW2	SW3	SW4	TG	VA	VD	WH	ZJ+
50	32	40	16	64.5	G1/4	14	8	17	M16x1.5	25	106	5	20	29.5	15	16	M8	17	8	3	24	46.5	4	6	37	143
63	32	45	16	75	G3/8	14	8	24	M16x1.5	26	121	5	20	36.5	21	28	M8	17	8	3	24	56.5	4	6	37	158
80	40	45	19	93	G3/8	14	8	24	M20x1.5	30	128	0	25	36	21	30	M10	22	*	5	30	72	4	7	46	174
100	40	55	19.5	110	G1/2	14	8	26	M20x1.5	35	138	0	25	38.5	23	40	M10	22	*	5	30	89	4	7	51	189
125	54	60	23	135	G1/2	14	10.5	30	M27x2	42	160	0	32	43	23.5	50	M12	27	12	4	41	110	6	8	65	225

Series 6PF cylinders - with rod lock



+ = add the stroke

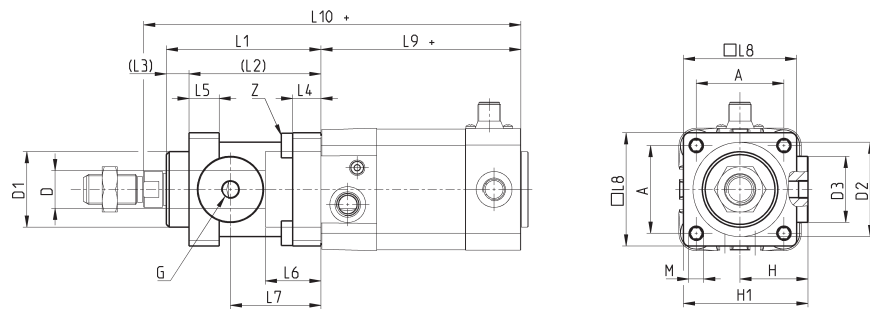

DIMENSIONS																					
Ø	gD	gD1	gD2	gD3	A	G	H	H1	L1	L2	L3	L4	L5	L6	L7	L8	L9+	L10+	M	Z	
50	20	40	50	35	46,5	G1/8	36	64	82	70	12	15	16	29,5	48	60	106	200	M8	M6x20	
63	20	45	60	38	56,5	G1/8	40	75	82	70	12	15	16	29,5	49,5	70	121	215	M8	M8x30	
80	25	45	80	48	72	G1/8	50	95	110	90	20	18	20	35	61	90	128	254	M10	M10x35	
100	25	55	100	58	89	G1/8	58	110,5	115	100	15	18	20	39	69	105	138	269	M10	M10x35	
125	32	60	130	65	110	G1/8	80	150	167	122	45	22	30	51	86,5	140	160	350	M12	M12x40	

Foot mount Mod. B

Material: zinc-plated steel



Supplied with:
2x feet
4x screws
+ = add the stroke

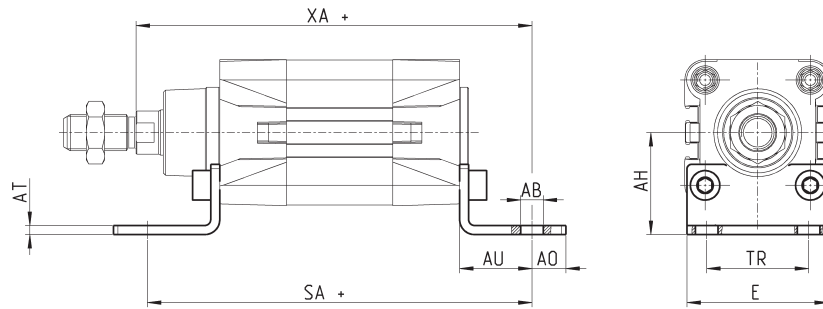

Mod.	∅	AT	SA+	XA+	TR	E	AB	AH	AO	AU	torque force
B-41-50	50	4	170	175	45	62,5	10	45	15	32	13 Nm
B-41-63	63	5	185	190	50	73	10	50	15	32	13 Nm
B-41-80	80	6	210	216	63	92	12	63	20	41	19 Nm
B-41-100	100	6	220	230	75	108,5	14,5	71	25	41	22 Nm
B-41-125	125	7	250	270	90	132	16,5	90	25	45	26 Nm

Front and rear flange Mod. D-E

Material: Aluminium

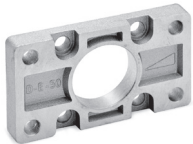

Supplied with:
1x flange
4x screws
+ = add the stroke

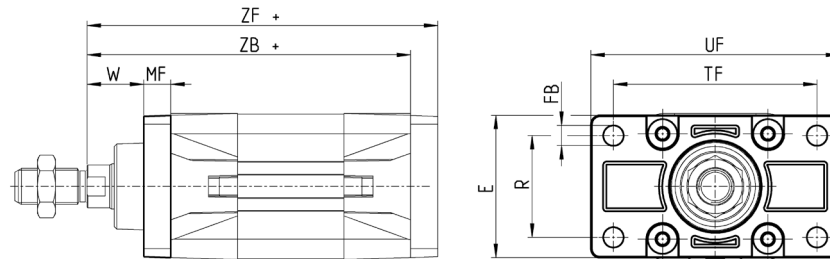

Mod.	∅	W	MF	ZB+	TF	R	UF	E	FB	ZF+	torque force
D-E-41-50	50	25	12	143	90	45	110	63	9	155	13 Nm
D-E-41-63	63	25	12	158	100	50	116	73	9	170	13 Nm
D-E-41-80	80	30	16	174	126	63	148	95	12	190	19 Nm
D-E-41-100	100	35	16	189	150	75	176	115	14	205	22 Nm
D-E-41-125	125	45	20	225	180	90	224	135	16	245	26 Nm

Rear female trunnion Mod. C and C-H

Material: Aluminium

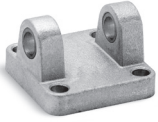

Supplied with:
1x female trunnion
4x screws

+ = add the stroke

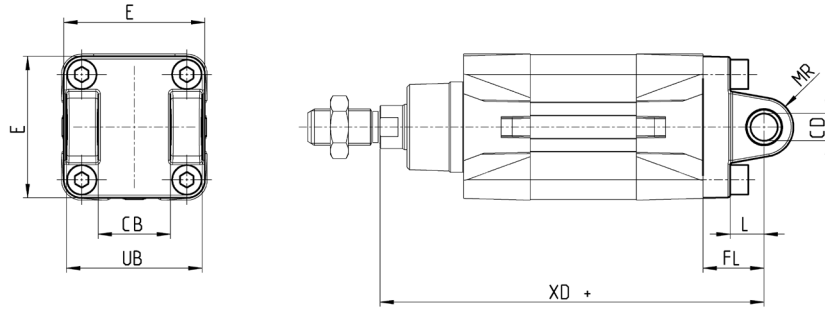

Mod.	∅	CD	L	FL	XD+	MR	E	CB	UB	torque force
C-41-50	50	12	15	27	170	13	63	32	60	13 Nm
C-H-41-63	63	16	20	32	190	15	73	40	70	13 Nm
C-H-41-80	80	16	24	36	210	15	95	50	90	19 Nm
C-H-41-100	100	20	29	41	230	18	115	60	110	22 Nm
C-H-41-125	125	25	30	50	275	25	135	70	130	26 Nm

Front female trunnion Mod. H and C-H

Material: Aluminium

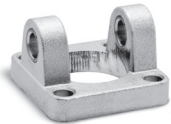

Supplied with:
1x female trunnion
4x screws

+ = add the stroke

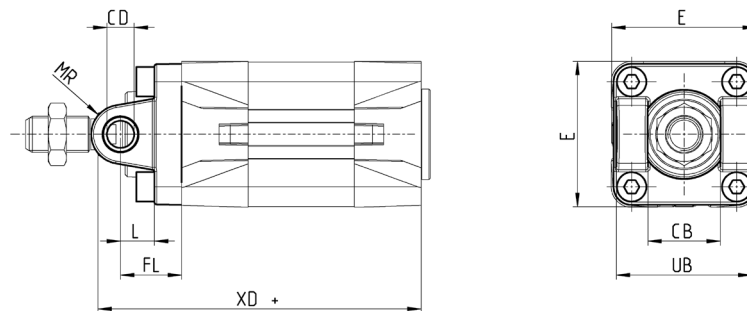

Mod.	∅	CB	UB	E	XD	FL	L	CD	MR	torque force
H-41-50	50	32	60	63	143	27	15	12	13	13 Nm
H-60-63	63	40	70	73	158	32	20	16	15	13 Nm
C-H-41-80	80	50	90	95	174	36	24	16	15	19 Nm
C-H-41-100	100	60	110	115	189	41	29	20	18	22 Nm
C-H-41-125	125	70	130	135	225	50	30	25	25	26 Nm

Rear male trunnion Mod. L

Material: Aluminium

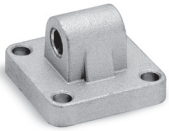

Supplied with:
1x male trunnion
4x screws

+ = add the stroke

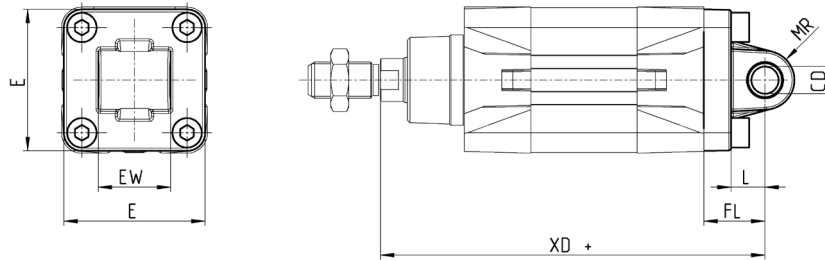

DIMENSIONS									
Mod.	∅	CD	L	FL	XD+	MR	E	EW	torque force
L-41-50	50	12	15	27	170	13	63	32	13 Nm
L-41-63	63	16	20	32	190	15	73	40	13 Nm
L-41-80	80	16	24	36	210	15	95	50	19 Nm
L-41-100	100	20	29	41	230	18	115	60	22 Nm
L-41-125	125	25	30	50	275	25	135	70	26 Nm

Centre trunnion Mod. F

Material: zinc-plated steel

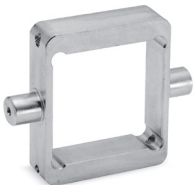

Supplied with:
1x centre trunnion
4x screws
4x fixing elements

+ = add the stroke

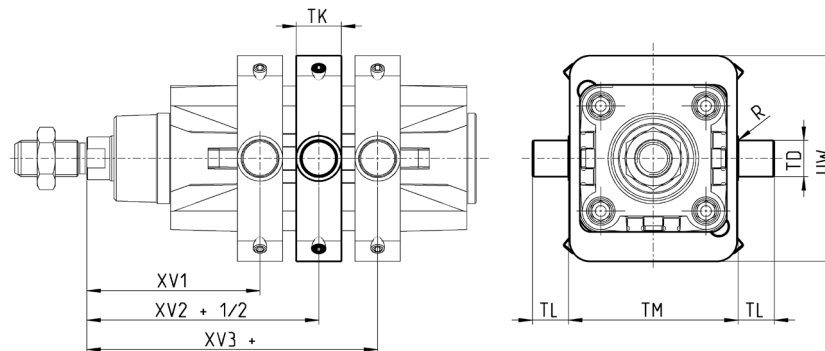

DIMENSIONS										
Mod.	∅	XV1	XV2	XV3	TM	TK	TD	TL	UW	R
F-61-50	50	76,5	90	103,5	75	20	16	16	91	0,15
F-61-63	63	86	97,5	109	90	25	20	20	94	0,15
F-61-80	80	94,5	110	125,5	110	25	20	20	130	0,15
F-61-100	100	104,5	120	135,5	132	30	25	25	145	0,2
F-61-125	125	123	145	167	160	30	25	25	155	0,2

Accessory combination Mod. C+L+S

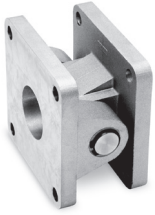

Material: aluminium

+ = add the stroke

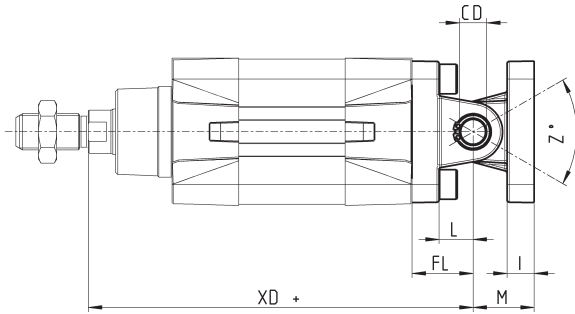
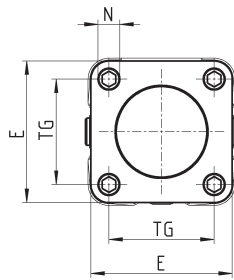

DIMENSIONS											
Mod.	∅	∅CD	L	FL	XD+	TG	E	I	M	∅N	torque force
C+L+S	50	12	15	27	170	46,5	63	13	27	9	13 Nm
C+L+S	63	16	20	32	190	56,5	73	15	32	9	13 Nm
C+L+S	80	16	24	36	210	72	95	15	36	11	19 Nm
C+L+S	100	20	29	41	230	89	115	18	41	11	22 Nm
C+L+S	125	25	30	50	275	110	135	25	50	13	26 Nm

90° male trunnion Mod. ZC

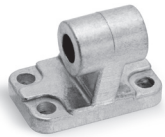

CETOP RP 107P
Material: Aluminium

Supplied with:
1x male support

+ = add the stroke

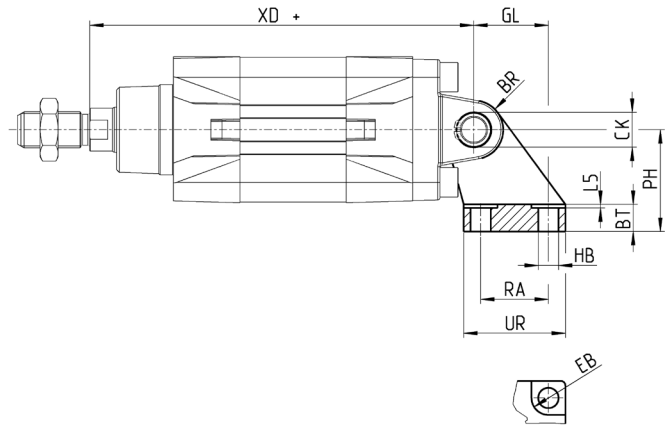
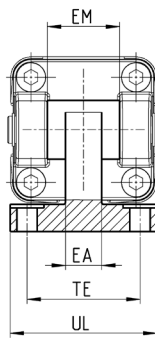

DIMENSIONS																
Mod.	∅	EB	CK	HB	XD+	TE	UL	EA	GL	L5	RA	EM	UR	PH	BT	BR
ZC-50	50	15	12	9	170	50	65	16	33	1,6	30	32	45	45	12	13
ZC-63	63	15	16	9	190	52	67	16	37	1,6	35	40	50	50	14	15
ZC-80	80	18	16	11	210	66	86	20	47	2,5	40	50	60	63	14	15
ZC-100	100	18	20	11	230	76	96	20	55	2,5	50	60	70	71	17	19
ZC-125	125	20	25	14	275	94	124	30	70	3,2	60	70	90	90	20	22,5

Trunnion ball-joint Mod. R*

* This trunnion doesn't comply with the ISO 15552 standard
Material: Aluminium

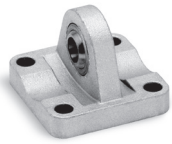

Supplied with:
1x trunnion ball joint
4x screws

+ = add the stroke

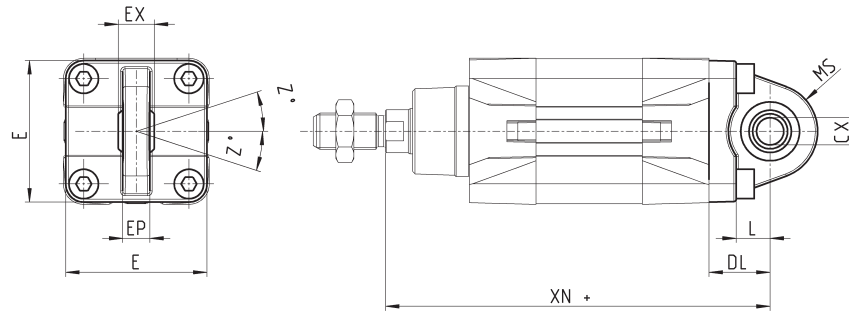

Mod.	∅	∅ _{CR}	L	DL	XN+	MS	E	EX	EP	Z	torque force
R-41-50	50	12 *	15	27	170	20	63	16 *	12 *	4	13 Nm
R-41-63	63	16	20	32	190	24	73	21	15	4	13 Nm
R-41-80	80	16 *	24	36	210	24	95	21 *	15 *	4	19 Nm
R-41-100	100	20	29	41	230	30	115	25	18	4	22 Nm
R-41-125	125	30	30	50	275	40	140	37	25	4	26 Nm

Counter bracket for centre trunnion Mod. BF

Material: Aluminium



Supplied with:
2x supports

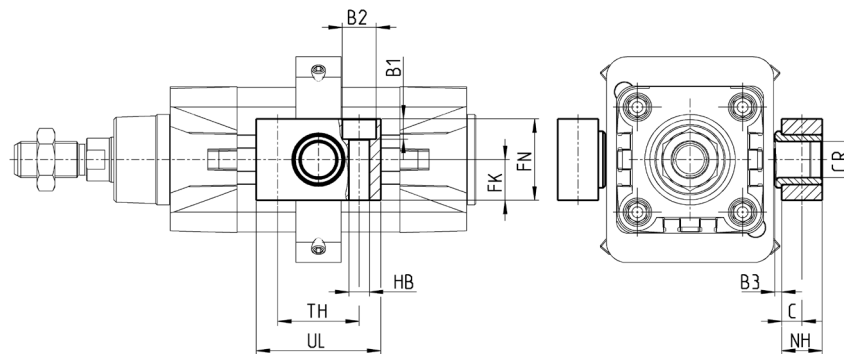

Mod.	∅	∅ _{CR}	NH	C	B3	TH	UL	FK	FN	B1	B2	HB
BF-40-50	50	16	18	9	3	36	55	18	36	9	15	9
BF-63-80	63 - 80	20	20	10	3	42	65	20	40	11	18	11
BF-100-125	100 - 125	25	25	12,5	3,5	50	75	25	50	13	20	14

Accessory to mount valves on the cylinder

The mounting sub-base Mod. PCV enables the valve or solenoid valve to be mounted directly on the cylinder.

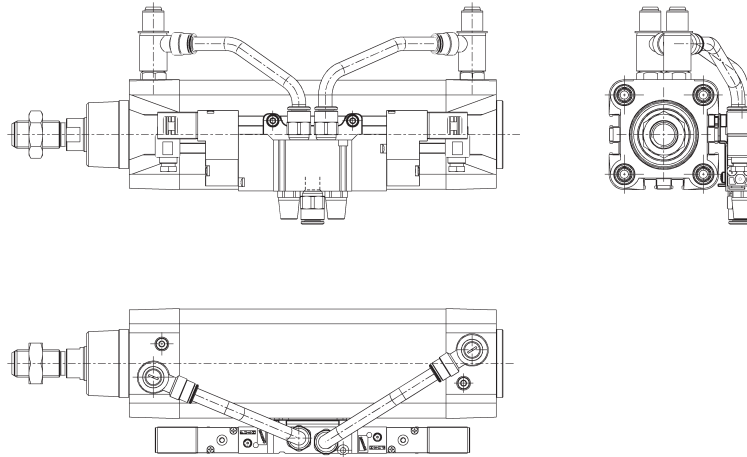

DIMENSIONS

Mod.

PCV-61-K3	to connect valves - solenoid valves Series 3
PCV-61-K4	to connect valves - solenoid valves Series 4 port G1/4
PCV-62-KEN	to connect valves - solenoid valves Series EN
PCV-61-K8	to connect valves - solenoid valves Series 4 port G1/8 and Series 3 port G1/4

Clevis pin Mod. S

Materials: Stainless steel 303 (clevis pin) / Steel (Seeger)



Supplied with:
1x clevis pin
2x Seeger

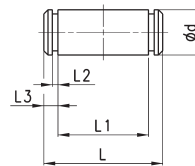

DIMENSIONS

Mod.	Ø	d	L	L1	L2	L3
S-50	50	12	67	61	1,1	3
S-63	63	16	77	71	1,1	3
S-80	80	16	97	91	1,1	3
S-100	100	20	121	111	1,3	5
S-125	125	25	140,5	132	1,3	4,25

Swivel ball joint Mod. GA



ISO 8139.
Material: zinc-plated steel.

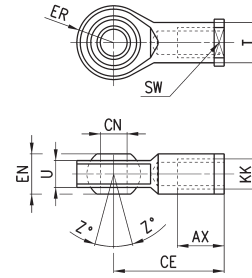

Mod.	\varnothing CN ^(M7)	U	EN	ER	AX	CE	KK	\varnothing T	Z	SW
GA-50-63	16	15	21	21	28	64	M16X1,5	22	7,5	22
GA-80-100	20	18	25	25	33	77	M20x1,5	27,5	7	30
GA-41-125	30	25	37	37	51	110	M27x2	40	7,5	41

Piston rod socket joint Mod. GY



Material: zama and zinc-plated steel.

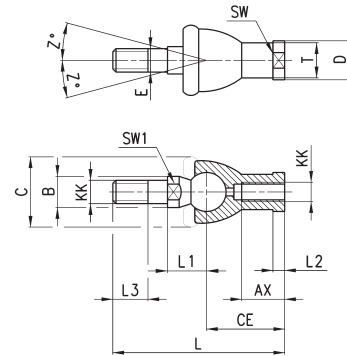

DIMENSIONS																
Mod.	\varnothing	KK	L	CE	L2	AX	SW	SW1	L1	L3	\varnothing T	\varnothing D	E	\varnothing B	\varnothing C	Z
GY-50-63	50-63	M16X1,5	112	50	8	27	22	19	27,5	23	22	27	16	22	40	11
GY-80-100	80-100	M20x1,5	133	63	10	38	30	24	31,5	25	27,5	34	20	27	45	7,5

Rod fork end Mod. G

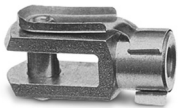

ISO 8140
Material: zinc-plated steel

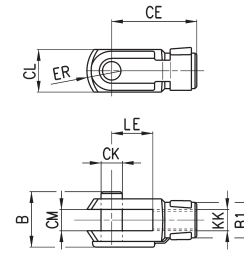

Mod.	\varnothing CK	LE	CM	CL	ER	CE	KK	B	\varnothing B1
G-50-63	16	32	16	32	19	64	M16 X 1,5	40	26
G-80-100	20	40	20	40	25	80	M20 X 1,5	48	34
G-41-125	30	54	30	55	38	110	M27 X 2	74	48

Piston rod lock nut Mod. U



ISO 4035
Material: zinc-plated steel.

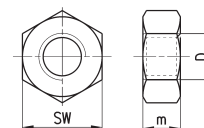

Mod.	D	m	SW
U-50-63	M16X1,5	8	24
U-80-100	M20x1,5	9	30
U-41-125	M27x2	12	41

Self aligning rod Mod. GK

Material: zinc-plated steel.

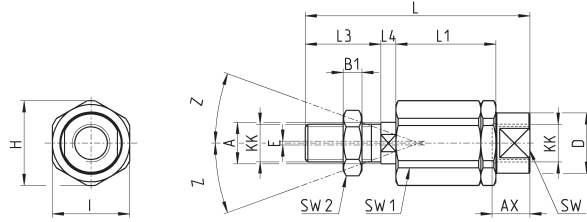

DIMENSIONS																	
Mod.	∅	KK	L	L1	L3	L4	$\varnothing A$	$\varnothing D$	H	I	SW	SW1	SW2	B1	AX	Z	E
GK-50-63	50-63	M16x1,5	104	53	32	10	22	32	45	41	27	20	24	8	30	3	2
GK-80-100	80-100	M20x1,5	119	53	40	10	22	32	45	41	27	20	30	10	37	3	2
GK-125	125	M27x2	147	60	54	10	32	57	70	65	54	24	41	12	48	4	2

Coupling piece Mod. GKF

Material: zinc-plated steel.

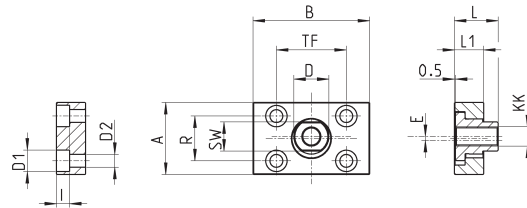
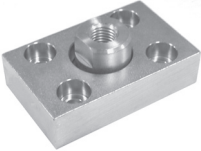

DIMENSIONS														
Mod.	∅	KK	A	B	R	TF	L	L1	I	∅ D	∅ D1	∅ D2	SW	E
GKF-50-63	50-63	M16x1,5	80	80	58	58	26,5	15	10,5	25	18	11	22	2,5
GKF-80-100	80-100	M20x1,5	90	90	65	65	32,5	20	13	30,5	20	14	27	2,5
GKF-125	125	M27x2	90	90	65	65	35,5	20	13	40	20	14	36	4

Special key to disassemble cylinders ∅ 80 and 100

Material: hardened steel

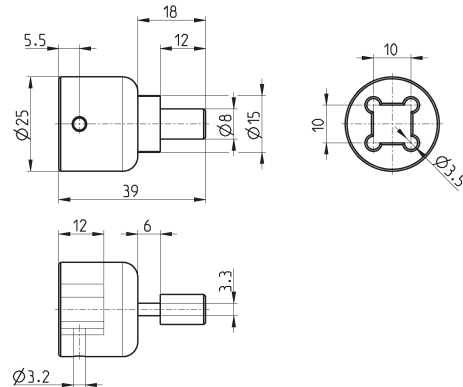
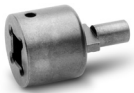

Mod.	80-62/8C
------	----------

Straight connector for power supply

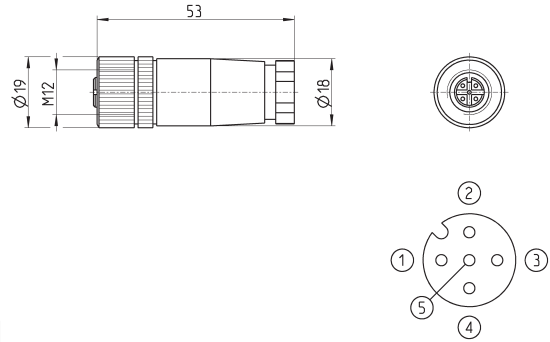

Mod.	description	type of connector	connection	cable length (m)
CS-LF04HB	for wiring	straight	M12 A 4 pin female - is not connected	Pin 5 -

Angular connector for power supply

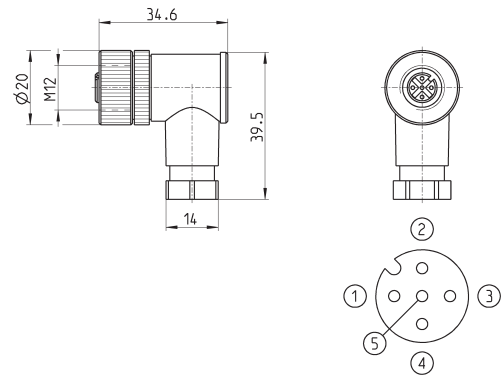

Mod.	description	type of connector	connection	cable length (m)
CS-LR04HB	for wiring	90°	M12 A 4 pin female - is not connected	Pin 5 -

Cable Mod. CS-LF05HB-D200/D500

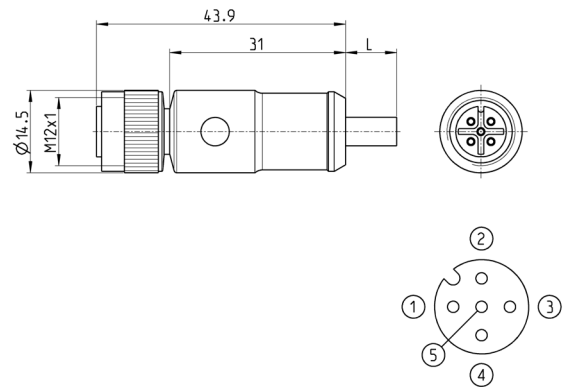

Mod.	Cable length (m)
CS-LF05HB-D200	2
CS-LF05HB-D500	5

Cable Mod. CS-LR05HB-D200/D500

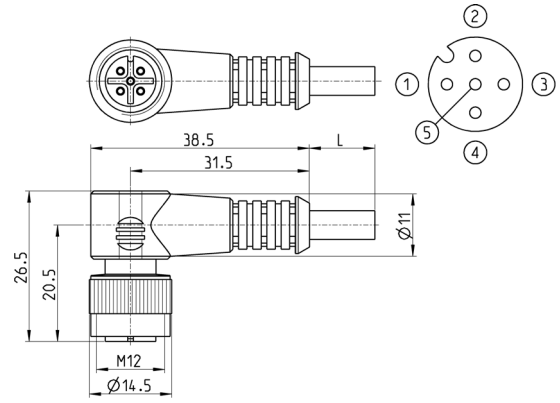

Mod.	Cable length (m)
CS-LR05HB-D200	2
CS-LR05HB-D500	5