

Series HN valve islands, Multipole and Fieldbus

Multipole connection with 25 or 37 pins
Serial connection with the most common communication protocols
Valve functions: 2x2/2; 2x3/2; 5/2; 5/3 CC



- » Valve flow: 400 and 850 Nl/min
- » Modular subbases: 2 positions for valve size 10.5mm, single position for valve size 21mm
- » Subbases for monostable and bistable valves (size 10.5mm)
- » Protocols available: PROFIBUS-DP, CANopen, DeviceNet, EtherNet/IP, PROFINET, EtherCAT

Thanks to the large range of options available, the Series HN valve islands represent an excellent solution for different applications, particularly in automation systems.

Small dimensions, high flow, pneumatic and electric modularity, electric connections on boards, possibility to interface with the multi-serial node Series CX, optimization of the signal distribution thanks to subbases for monostable and bistable solenoid valves are only some of the features that make this series a particularly innovative product.

Manuals, instruction sheets and configuration files can be found on catalogue.camozzi.com or on the QR code on the label of the product.

GENERAL DATA

PNEUMATIC SECTION	
Valve construction	spool with seals
Valve functions	5/2 monostable and bistable 5/3 CC 2 x 2/2 NO 2 x 2/2 NC 1 x 2/2 NC+ 1 x NO 2 x 3/2 NC 2 x 3/2 NO 1 x 3/2 NC+ 1 x 3/2 NO
Materials	spool in aluminium spool seals in HNBR other seals in NBR cartridges in brass body and end covers in technopolymer subbases in aluminium
Connections	Inlets 2 and 4, size 10,5 mm: M7, tube Ø 4, tube Ø 6, tube Ø 8 Inlets 2 and 4, size 21 mm: G1/4, tube Ø 10 Supply 1: G1/4, tube Ø 8, tube Ø 10 Supply 12/14: M7 Exhausts 3 and 5: G1/4 or with integrated silencer Exhausts 82/84: M7
Temperature	0 ÷ 50°C
Air specifications	Filtered compressed air, non lubricated, class 6.4.4 according to ISO 8573-1:2010. If lubrication is necessary, please only use oils with maximum viscosity of 32 Cst and the version with external servo-pilot supply. The servo-pilot supply air quality class must be 6.4.4 according to ISO 8573-1:2010 (do not lubricate).
Valve sizes	10.5mm (2 valves for each subbase) 21mm (1 valve for each subbase)
Working pressure	- 0,9 ÷ 10 bar
Pilot pressure	3 ÷ 7 bar 4.5 ÷ 7 bar (with working pressure exceeding 6 bar for the versions 2x2/2 and 2x3/2)
Flow rate	400 NL/min (10.5mm) 850 NL/min (21mm)
Mounting position	any position
Protection class	IP 65
ELECTRICAL SECTION - MULTIPOLE VERSION	
Type of Sub-D connector	25 or 37 pins
Max. absorption	0.8 A (with Sub-D connector 25 pins) 1 A (with Sub-D connector 37 pins)
Supply voltage	24 V DC +/- 10%
Max. number of coils to operate	24 on 20 valve positions (with Sub-D connector 25 pins) 32 on 28 valve positions (with Sub-D connector 37 pins)
Valve signalling	yellow led
ELECTRICAL SECTION - FIELDBUS VERSION	
General data	see the CX section
Max. absorption	digital outputs / analog outputs and inputs 3A digital/analog inputs 3A
Supply voltage	logic supply 24 V DC +/- 10% power supply 24 V DC +/- 10%
Max. number of coils to operate	32 on 28 valve positions

VERSIONS: MULTIPOLE and MULTIPOLE WITH SUB-D ADAPTOR

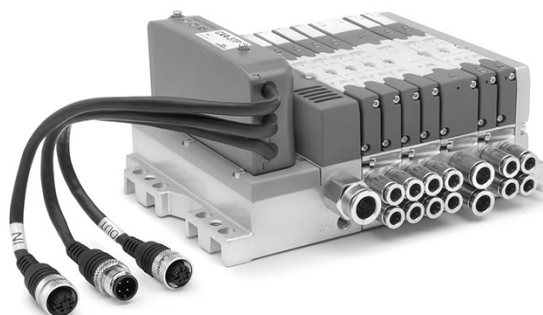
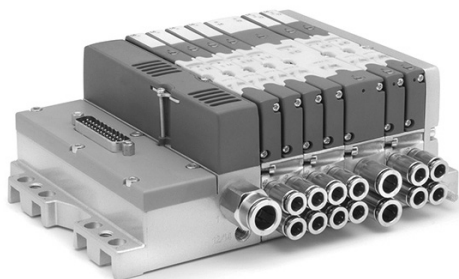

The Multipole version can be connected in a quick and secure way thanks to the electrical connection by means of a pre-wired cable with 25 or 37 pins with in-line or angular connection. It is possible to create zones with differentiated power supply and with separate pressure/exhaust. Thanks to the subbases with monostable board, islands can be realized up to maximum of 24 coils on 20 valve positions with the 25 pin connection and 32 coils on 28 valve positions with the 37 pin connection.

The Multipole Island of both 25 pins and 37 pins can be connected by means of a Sub-D adaptor, also of 25 or 37 pins. In this way a standard Multipole Island can be inserted as expansion in the subnet of the Serial version.

VERSIONS: FIELDBUS WITH CPU MODULE AND EXPANSION FIELDBUS

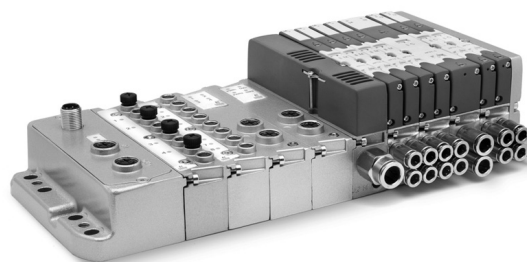
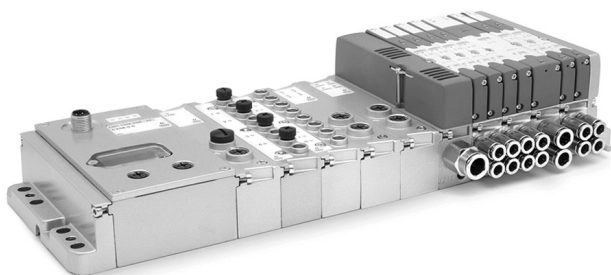

Thanks to the Series CX Multi-serial node and a special direct interface module with the pneumatic part of the island, it is possible to interface the Series HN with the PROFIBUS-DP, DeviceNet, CANopen, PROFINET, EtherCAT and EtherNet/IP serial protocols. The Fieldbus version with CPU has the same configuration rules of a Multipole island and can be equipped with different electric modules like digital/analog inputs/outputs of 0-10V and 4-20mA, as well as initial subnet Modules.

It is possible to insert Initial Subnet Modules in the version with CPU module. These Modules enable to create a subnet with tree structure or in series. On the subnet you can connect Expansion Islands. These expansions have the same possibilities to use the different electric modules, like digital and analog inputs and outputs and further Initial Subnet Modules. Also with this version the same rules as the CPU module and Multipole apply.

MULTIPOLE VERSION CODING EXAMPLE

HN	5	M	-	03A	-	2Q4AZ2A	-	2B8M4C	-	A
-----------	----------	----------	----------	------------	----------	----------------	----------	---------------	----------	----------

HN	SERIES														
5	SIZE: 1 = 10.5 2 = 21 5 = Mixed														
M	ELECTRICAL CONNECTION: M = Multipole 25 pin PNP N = Multipole 25 pin NPN H = Multipole 37 pin PNP L = Multipole 37 pin NPN														
03A	CONNECTION: 000 = without connector/cable			CONNECTOR WITH CABLE AXIAL OUTPUT: 03A = 3m 05A = 5m 10A = 10m 15A = 15m 20A = 20m 25A = 25m			CONNECTOR WITHOUT CABLE: 4XA = 25 pins axial 4XR = 25 pins radial 9XA = 37 pins axial 9XR = 37 pins radial			CONNECTOR WITH CABLE RADIAL OUTPUT: 03R = 3m 05R = 5m 10R = 10m 15R = 15m 20R = 20m 25R = 25m					
2Q4AZ2A	SUBBASES FOR 2 SOLENOID VALVES SIZE 1 (*): A (AZ) = M7 threads B (BZ) = 4 fittings for tube Ø4 C (CZ) = 4 fittings for tube Ø6 D (DZ) = channel 1, 3, 5 closed; M7 threads E (EZ) = channel 1, 3, 5 closed; fittings tube Ø4 F (FZ) = channel 1, 3, 5 closed; fittings tube Ø6 G (GZ) = channel 3, 5 closed; M7 threads H (HZ) = channel 3, 5 closed; fittings tube Ø4 I (IZ) = channel 3, 5 closed; fittings tube Ø6 L (LZ) = channel 1 closed; M7 threads M (MZ) = channel 1 closed; fittings tube Ø4 N (NZ) = channel 1 closed; fittings tube Ø6 (*) Subbases with "Z" at the end of their code are used with monostable solenoid valves FOR SOLENOID VALVES SIZE 2: Q = G1/8 threads R = fittings for tube Ø6 S = fittings for tube Ø8 P = G1/4 threads J = fittings for tube Ø10					SUBBASES FOR PNEUMATIC SUPPLY: X = supplementary supply and exhaust Y = supplementary supply and exhaust with integrated silencer W = supply from the exhausts FOR ELECTRICAL SUPPLY: K = separation of electrical supply					SEALS: T = diaphragm on channels 1, 3, 5 U = diaphragm on channel 1 V = diaphragm on channels 3, 5				
2B8M4C	SOLENOID VALVES Size 1 and 2: 0 = island without solenoid valves M = 5/2 Monostable B = 5/2 Bistable V = 5/3 Centres Closed C = 2 x 3/2 NC A = 2 x 3/2 NO G = 1 x 3/2 NC + 1 x 3/2 NO E = 2 x 2/2 NC F = 2 x 2/2 NO I = 1 x 2/2 NC + 1 x 2/2 NO L = free position					SOLENOID VALVE + PRESSURE REGULATOR on channel 1 (size 2 only): N = 5/2 Monostable P = 5/2 Bistable Q = 5/3 Centres Closed R = 2 x 3/2 NC S = 2 x 3/2 NO T = 1 x 3/2 NC + 1 x 3/2 NO U = 2 x 2/2 NC X = 2 x 2/2 NO Y = 1 x 2/2 NC + 1 x 2/2 NO									
A	THREADED TERMINAL PLATES: A = 1, 12/14 in common 3/5, 82/84 threaded ports B = 1, 12/14 separated 3/5, 82/84 threaded ports C = 1, 12/14 in common 3/5, 82/84 with integrated silencer D = 1, 12/14 separated 3/5, 82/84 with integrated silencer					TERMINAL PLATES with FITTINGS FOR TUBE Ø 8 on PORT 1: E = 1, 12/14 in common 3/5, 82/84 conveyable F = 1, 12/14 separated 3/5, 82/84 conveyable G = 1, 12/14 in common 3/5, 82/84 with integrated silencer H = 1, 12/14 separated 3/5, 82/84 with integrated silencer					TERMINAL PLATES with FITTINGS FOR TUBE Ø 10 on PORT 1: I = 1, 12/14 in common 3/5, 82/84 conveyable L = 1, 12/14 separated 3/5, 82/84 conveyable M = 1, 12/14 in common 3/5, 82/84 with integrated silencer N = 1, 12/14 separated 3/5, 82/84 with integrated silencer				

In presence of identical consequent codes both for the subbases as for the valves you need to substitute the letter with the number.
 Ex: HN5M-03A-ABCS-MMCCBBB-A is converted to HN5M-03A-ABCS-2M2C3B-A.

MULTIPOLE VERSION CODING

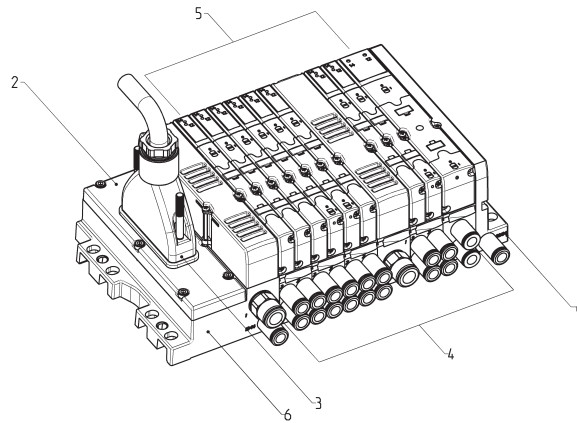

1 2 3 4 5 6
 H N 5 M - 0 3 A - 3 B X B R - 3 M 2 B M X M V C - D

SIZE (1)	ELECTRICAL CONNECTION (2)	CONNECTION (3)	SUBBASES for 2 solenoid valves, size 1 (4)	SOLENOID VALVES Size 1 and 2 (5)	THREADED TERMINAL PLATES (6)
1	M	000	A / AZ	O	A
2	N	03A	B / BZ	M	B
5	H	05A	C / CZ	B	C
		10A	D / DZ	V	D
	L	15A	E / EZ	C	TERMINAL PLATES fittings for tube Ø8, on port 1
		20A	F / FZ	A	E
		25A	G / GZ	G	F
		03R	H / HZ	E	G
		05R	I / IZ	F	H
		10R	L / LZ	I	TERMINAL PLATES fittings for tube Ø10, on port 1
		15R	M / MZ	L	I
		20R	N / NZ		L
		25R	SUBBASES for solenoid valves, size 2	SOL. VALVE + PRESS. REG. channel 1, size 2 only	M
		4XA	Q	N	N
		4XR	R	P	
		9XA	S	Q	
		9XR	P	R	
			J	S	
			SUBBASES FOR PNEUMATIC SUPPLY	T	
			X	U	
			Y	X	
			W	Y	
			SUBBASES FOR ELECTRICAL SUPPLY		
			K		
			SEALS		
			T		
			U		
			V		

SERIES HN VALVE ISLANDS

FIELDBUS VERSION CODING EXAMPLE

HN	5	01	-	ABCD	-	2Q4AZ2A	-	2B8M4C	-	A
-----------	----------	-----------	----------	-------------	----------	----------------	----------	---------------	----------	----------

HN	SERIES									
5	SIZE: 1 = 10.5 2 = 21 5 = Mixed									
01	PROTOCOL: 01 = PROFIBUS-DP 02 = DeviceNet 03 = CANopen 04 = EtherNet/IP 05 = EtherCAT 06 = PROFINET 99 = Expansion module									
ABCD	INPUT / OUTPUT MODULES: 0 = no module			INPUT / OUTPUT MODULES: A = 8 Digital Inputs M8 B = 4 Digital Inputs M8 C = 2 Analog Inputs 4-20mA D = 2 Analog Inputs 0-10V E = 1 Analog Input 4-20mA + 1 Input 0-10V Q = 4 Digital Outputs M12 duo R = 2 Analog Outputs 4-20mA T = 2 Analog Outputs 0-10V U = 1 Analog Output 4-20mA + 1 Output 0-10V V = 1 Analog Output 4-20mA + 1 Input 0-10V Z = 1 Analog Output 4-20mA + 1 Input 4-20mA K = 1 Analog Output 0-10V + 1 Input 0-10V Y = 1 Analog Output 0-10V + 1 Input 4-20mA				INPUT / OUTPUT MODULES: S = Initial subnet module		
2Q4AZ2A	SUBBASES FOR 2 SOLENOID VALVES SIZE 1 (*): A (AZ) = M7 threads B (BZ) = 4 fittings for tube Ø4 C (CZ) = 4 fittings for tube Ø6 D (DZ) = channel 1, 3, 5 closed; M7 threads E (EZ) = channel 1, 3, 5 closed; fittings tube Ø4 F (FZ) = channel 1, 3, 5 closed; fittings tube Ø6 G (GZ) = channel 3, 5 closed; M7 threads H (HZ) = channel 3, 5 closed; fittings tube Ø4 I (IZ) = channel 3, 5 closed; fittings tube Ø6 L (LZ) = channel 1 closed; M7 threads M (MZ) = channel 1 closed; fittings tube Ø4 N (NZ) = channel 1 closed; fittings tube Ø6 (*) Subbases with "Z" at the end of their code are used with monostable solenoid valves FOR SOLENOID VALVES SIZE 2: Q = G1/8 threads R = fittings for tube Ø6 S = fittings for tube Ø8 P = G1/4 threads J = fittings for tube Ø10					SUBBASES FOR PNEUMATIC SUPPLY: X = supplementary supply and exhaust Y = supplementary supply and exhaust with integrated silencer W = supply from the exhausts FOR ELECTRICAL SUPPLY: K = separation of electrical supply			SEALS: T = diaphragm on channels 1, 3, 5 U = diaphragm seal on channel 1 V = diaphragm seal on channels 3, 5	
2B8M4C	SOLENOID VALVES Size 1 and 2: 0 = island without solenoid valves M = 5/2 Monostable B = 5/2 Bistable V = 5/3 Centres Closed C = 2 x 3/2 NC A = 2 x 3/2 NO G = 1 x 3/2 NC + 1 x 3/2 NO E = 2 x 2/2 NC F = 2 x 2/2 NO I = 1 x 2/2 NC + 1 x 2/2 NO L = free position					SOLENOID VALVE + PRESSURE REGULATOR on channel 1 (size 2 only): N = 5/2 Monostable P = 5/2 Bistable Q = 5/3 Centres Closed R = 2 x 3/2 NC S = 2 x 3/2 NO T = 1 x 3/2 NC + 1 x 3/2 NO U = 2 x 2/2 NC X = 2 x 2/2 NO Y = 1 x 2/2 NC + 1 x 2/2 NO				
A	THREADED TERMINAL PLATES: A = 1, 12/14 in common 3/5, 82/84 threaded ports B = 1, 12/14 separated 3/5, 82/84 threaded ports C = 1, 12/14 in common 3/5, 82/84 with integrated silencer D = 1, 12/14 separated 3/5, 82/84 with integrated silencer			TERMINAL PLATES with FITTINGS Ø8: E = 1, 12/14 in common 3/5, 82/84 conveyable F = 1, 12/14 separated 3/5, 82/84 conveyable G = 1, 12/14 in common 3/5, 82/84 with integrated silencer H = 1, 12/14 separated 3/5, 82/84 with integrated silencer			TERMINAL PLATES with FITTINGS Ø10: I = 1, 12/14 in common 3/5, 82/84 conveyable L = 1, 12/14 separated 3/5, 82/84 conveyable M = 1, 12/14 in common 3/5, 82/84 with integrated silencer N = 1, 12/14 separated 3/5, 82/84 with integrated silencer			

X, Y and K sub-bases will be equipped with threads or cartridges of the same size of port 1, see the choice "Type of terminal plates". In presence of identical consequent codes both for sub-bases and for valves, you need to substitute the letter with the number.
 Ex: HN501-ABCD-ABCS-MMCBBB-A is converted to HN501-ABCD-ABCS-2M2C3B-A.

FIELDBUS VERSION CODING

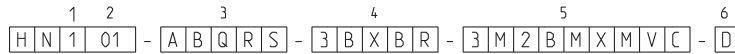
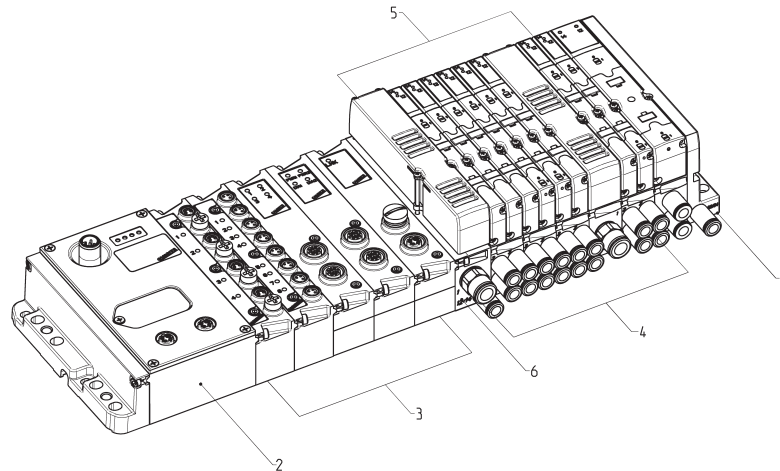

HN...								
SIZE (1)	PROTOCOL (2)	INPUT / OUTPUT MODULES (3)	SUBBASES FOR 2 SOLENOID VALVES, size 1 (4)	SOLENOID VALVES Size 1 and 2 (5)	THREADED TERMINAL PLATES (6)			
1	01	0	A / AZ	0	A			
2	02	A	B / BZ	M	B			
5	03	B	C / CZ	B	C			
	04	C	D / DZ	V	D			
	05	D	E / EZ	C	TERMINAL PLATES cartridges Ø8			
	06	E	F / FZ	A		E		
	99	Q	G / GZ	G	F			
		R	H / HZ	E	G			
		T	I / IZ	F	H			
		U	L / LZ	I	TERMINAL PLATES cartridges Ø10			
		V	M / MZ	L		I		
		Z	N / NZ		L			
		K	SUBBASES for SOLENOID VALVES, size 2	SOL. VALVE + PRESS. REG. channel 1, size 2 only	M			
		Y	Q	N	N			
		S	R	P				
			S	Q				
			P	R				
			J	S				
			SUBBASES FOR PNEUMATIC SUPPLY	T				
			X	U				
			Y	X				
			W	Y				
			SUBBASES FOR ELECTRICAL SUPPLY					
			K					
			SEALS					
			T					
			U					
			V					

SERIES HN VALVE ISLANDS

MULTIPOLE version COMPONENTS

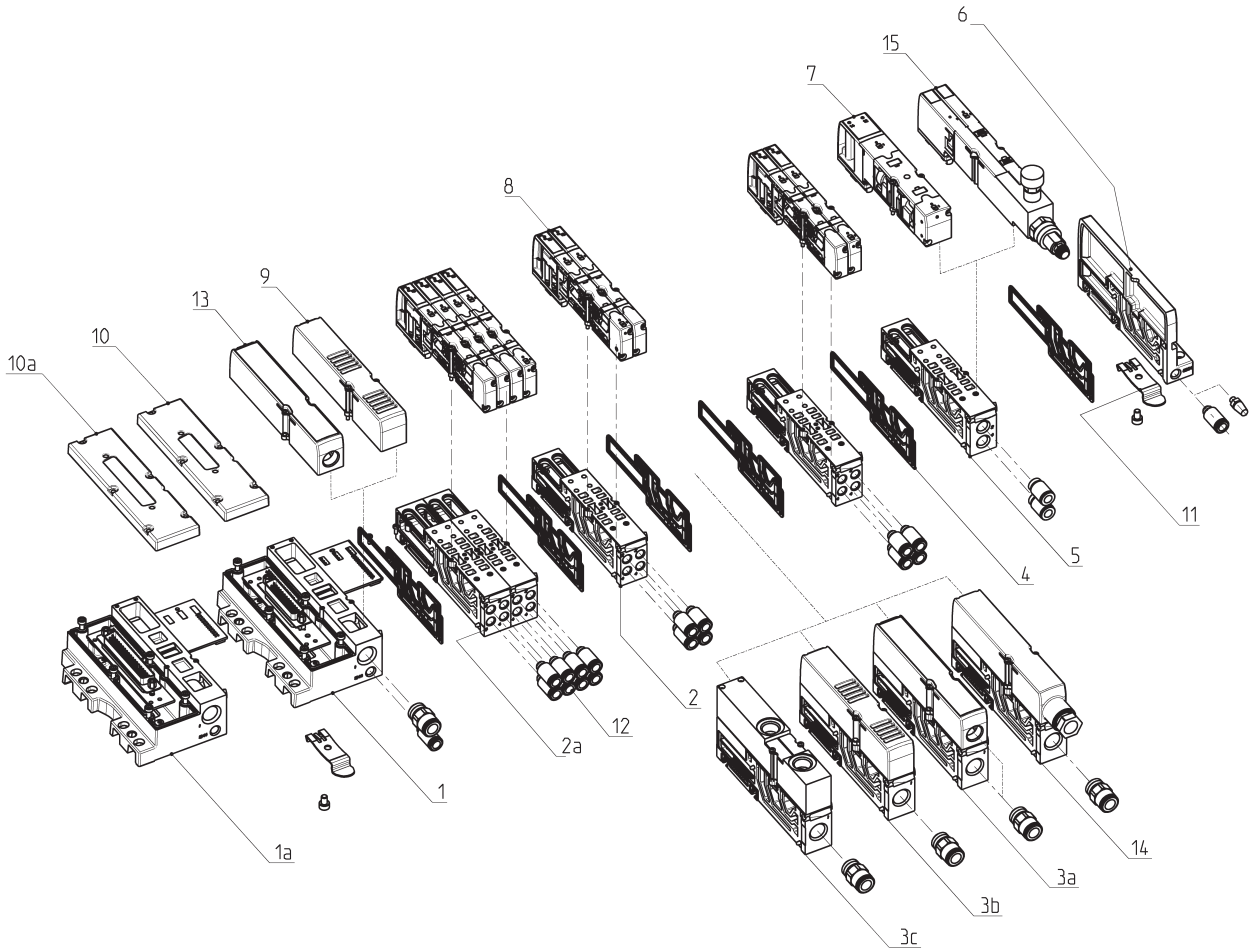

COMPONENTS			
1	Electric interface group Multipole 25 pin	7	Solenoid valve, size 2
1a	Electric interface group Multipole 37 pin	8	Solenoid valve, size 1
2	Threaded subbase, size 10.5 - modularity 2	9	Cover with silencer
2a	Subbases without electric board	10	Multipole electric cover 25 pins
3a	Conveyable plate for supply and supplementary exhaust	10a	Multipole electric cover 37 pins
3b	Plate for supply and exhaust with silencer	11	Mounting bracket for DIN rail
3c	Plate for supply from exhausts	12	Quick-release fittings
4	Interface seals	13	Cover to convey exhausts 3 and 5
5	Threaded subbase, size 21 - modularity 1	14	Module to separate electrical supply and supplementary pneumatic supply
6	Right terminal (HAOT-H)	15	Valve size 10.5 with incorporated pressure regulator

MULTI-SERIAL version and EXPANSION MODULE COMPONENTS

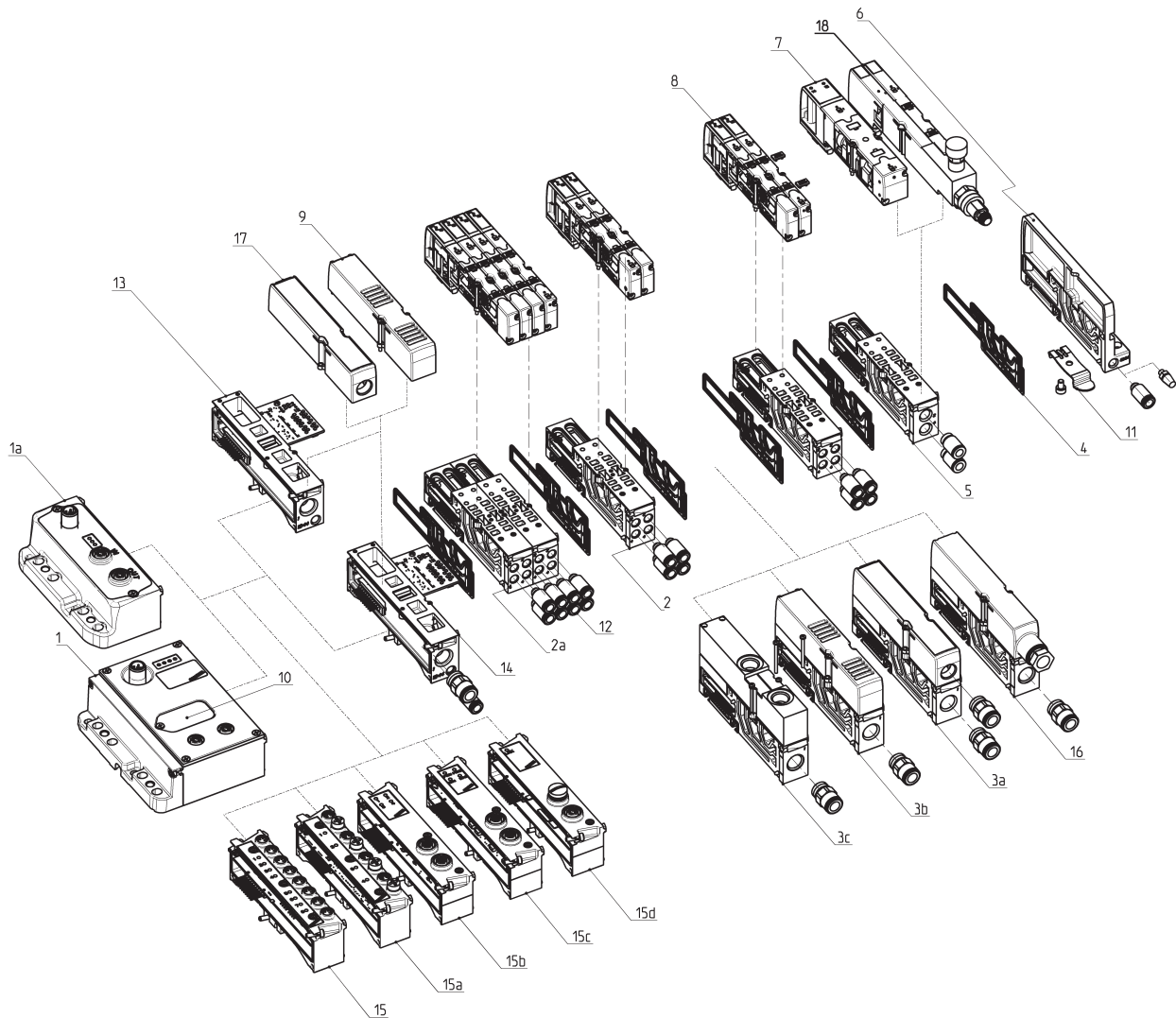

COMPONENTS			
1	Multi-serial Module CX	11	Mounting bracket for DIN rail
1a	Expansion Module		
2	Threaded subbase, size 10.5 - modularity 2	12	Quick-release fittings
2a	Subbases without electric board		
3a	Conveyable plate for supply and supplementary exhaust	13	Direct interface module with Series HN with internal pilot supply
3b	Plate for supply and exhaust with silencer		
3c	Plate for supply from exhausts		
4	Interface seals	14	Direct interface module with Series HN with external pilot supply
5	Threaded subbase, size 21 - modularity 1	15	8 Digital Inputs module
		15a	4 Digital Inputs module
6	Right terminal (HAOT-H)	15b	4 Digital Outputs module
		15c	IN/OUT analog module
		15d	Initial subnet module
7	Solenoid valve size 2	16	Cover to convey exhausts 3 and 5
8	Solenoid valve size 1	17	Module to separate electrical supply and supplementary pneumatic supply
9	Cover with silencer	18	Valve size 10,5 with integrated pressure regulator
10	Cover for the access to rotary switches and for programming		

AVAILABLE FUNCTION - SYMBOLS FOR SOLENOID VALVES

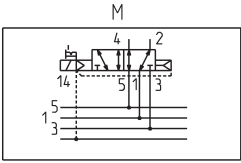

M = 5/2-way, Monostable

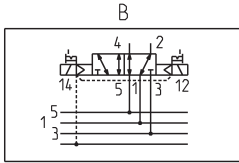

B = 5/2-way, Bistable

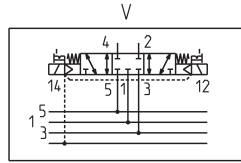

V = 5/3-way Centres Closed

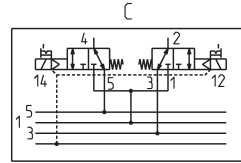

C = 2 x 3/2-way NC

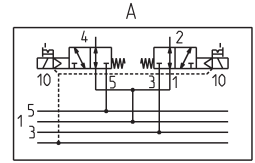

A = 2 x 3/2-way NO

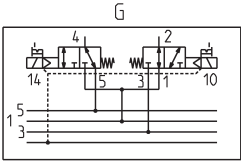

G = 1 x 3/2-way NC +
1 x 3/2-way NO

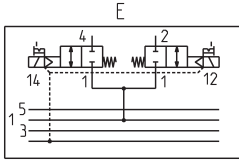

E = 2 x 2/2-way NC

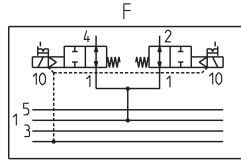

F = 2 x 2/2-way NO

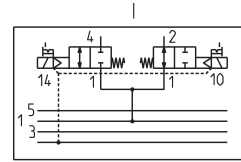

I = 1 x 2/2-way NC +
1 x 2/2-way NO

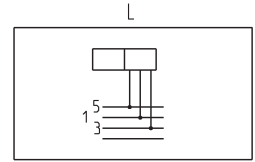

L = free position

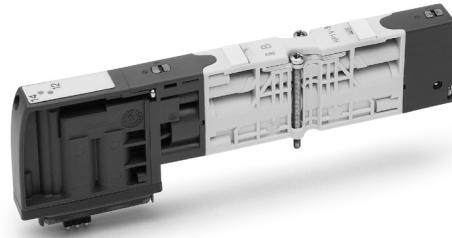

AVAILABLE FUNCTIONS - SYMBOLS FOR SOLENOID VALVES WITH PRESSURE REGULATOR

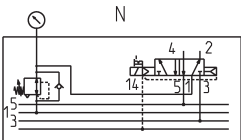

N = 5/2-way, Monostable

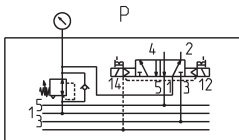

P = 5/2-way, Bistable

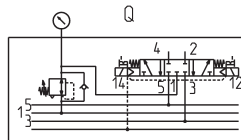

Q = 5/3-way Centres Closed

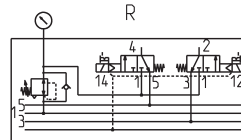

R = 2 x 3/2-way NC

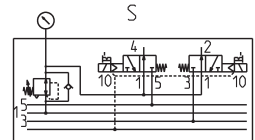

S = 2 x 3/2-way NO

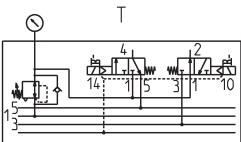

T = 1 x 3/2-way NC +
1 x 3/2-way NO

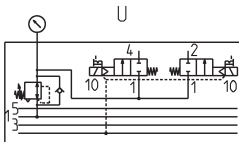

U = 2 x 2/2-way NC

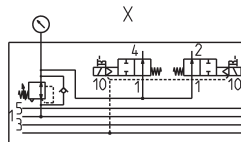

X = 2 x 2/2-way NO

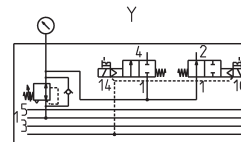

Y = 1 x 2/2-way NC +
1 x 2/2-way NO

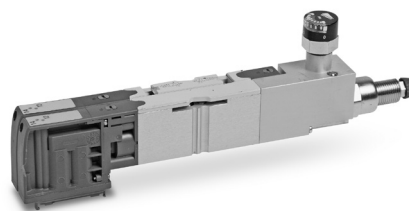

It can be assembled on subbase size 21 only.

AVAILABLE FUNCTIONS - SUBBASE TYPES

SERIES HN VALVE ISLANDS



Through-subbase s. 10.5
A=M7, B=Ø4, C=Ø6 [*]



Diaphragm lines 1, 3 5
D=M7, E=Ø4, F=Ø6 [*]



Diaphragm line 1
L=M7, M=Ø4, N=Ø6 [*]



Diaphragm lines 3, 5
G=M7, H=Ø4, I=Ø6 [*]



Through-subbase s. 21
Q = 1/8, R = Ø6, S = Ø8



X = supplementary supply and exhaust



K = intern. plate to sep. elec. and suppl. supply



Y = supplem. supply + exhaust with silencer



Z = electro-pneum. interface for HP...F/G/R

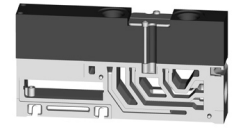

W = plate for supply from exhausts



U = Diaphragm seal - Line 1



V = Diaphragm seal - Lines 3, 5



P = Through seal



T = Diaphragm seal - Lines 1, 3, 5

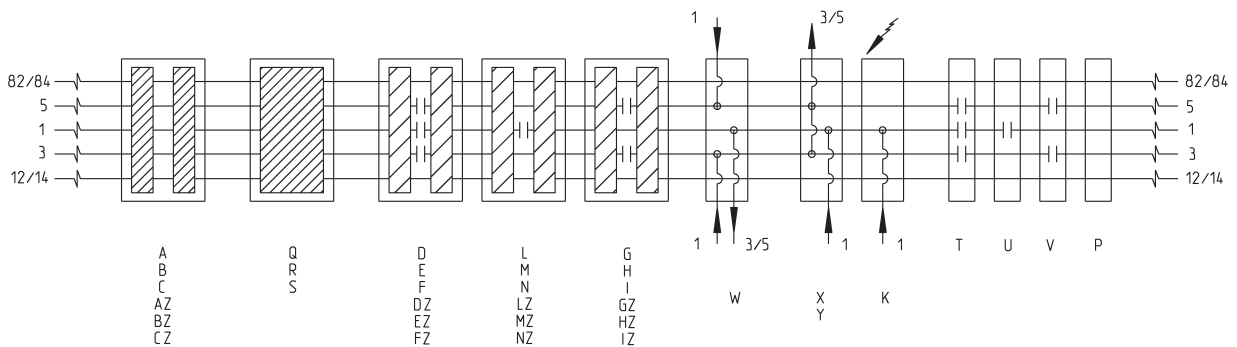

[*] The subbases A, B, C, D, E, F, G, H, I, L, M, N are available also with a board to be used with monostable solenoid valves. To order this version it is necessary to add Z at the end of the code of the standard subbase. Example: AZ instead of A. For further details we suggest you to see the coding example.

PROPER USE OF VALVE FUNCTIONS WITH INTERMEDIATE PLATE TYPE W

The intermediate plate cod. W is composed by a subbase which is equipped with an upper connection bracket. On this bracket there are two connections on which it is possible to apply two different pressures (ex. P2 and P3). In this configuration, the connection 1 on the subbase represents the exhaust 3/5. With this plate it is possible to supply the valves positioned downstream through the exhausts 3 and 5. When supplied from the exhausts, these valves have a different function compared with the ones supplied in the standard way. Some examples: Solenoid valve mod. C at rest has outlets 2 and 4 active and corresponds to model "A", in presence of electrical inputs 12 and 14 outlets 2 (P3) and 4 (P2) close respectively; the configuration of solenoid valve mod. V at rest doesn't change, in presence of electrical input 12 outlet 4 (P2) is activated, in presence of electrical input 14 outlet 2 (P3) is activated; outlets 2 and 4 are closed in solenoid valve mod. A at rest which corresponds to model "C", in presence of electrical inputs 12 and 14 outlets 2 (P3) and 4 (P2) open respectively; outlet 4 (P2) is active in solenoid valve mod. M at rest, in presence of electrical input 14 the active outlet becomes outlet 2 (P3). All the valve functions, both 10.5 and 21 sizes, have this different operation. Solenoid valves with an integrated pressure regulator can't be used after an intermediate plate W. This plate requires in the initial part of the valve island a supply pressure of 4 bar at least. Otherwise, it is necessary to use the version with external servo pilot supply and apply a pressure of at least 4 bar on the connection 12/14. It is necessary to insert a seal type T before plate W.

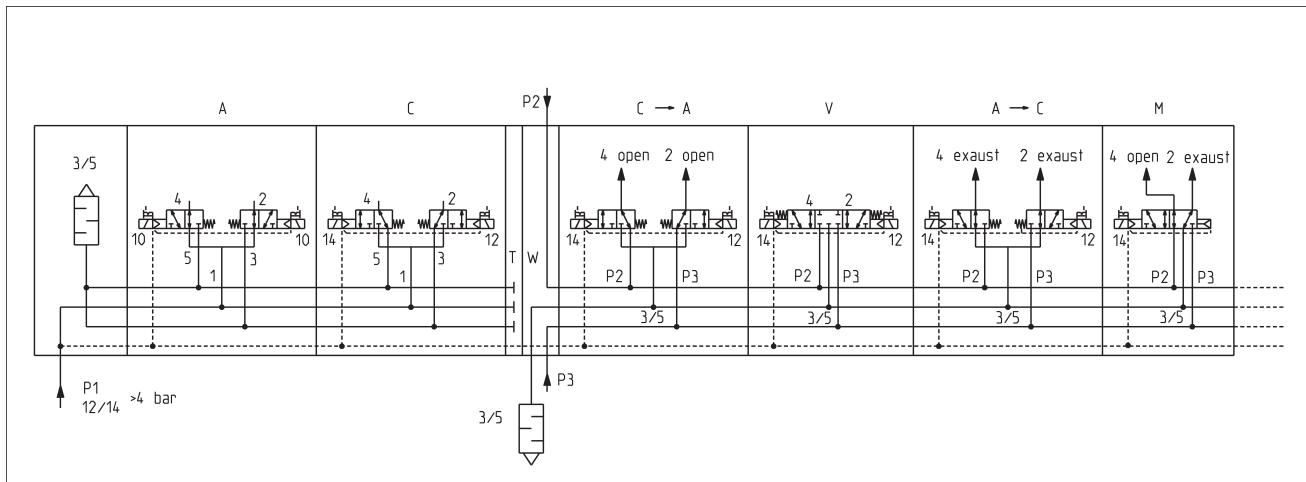

SUBBASES WITH MONOSTABLE BOARD

The subbases for valves Size 1 (10.5 mm) are set for housing 2 solenoid valves that may be both with double solenoid. Each subbase uses 4 electric signals. Even in case of monostable solenoid valves the subbase uses 4 electrical signals. To increase the number of valve positions that can be connected with a single Sub-D connector, all the subbases Size 1 can add "Z" at the end of their code thus using 2 electrical signals. They are, therefore, suitable for the connection of monostable solenoid valves.

Examples:

- Code A --> AZ with board for monostable solenoid valves
- Code N --> NZ with board for monostable solenoid valves

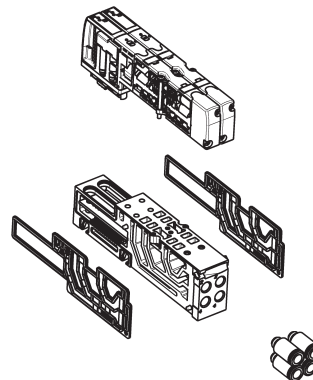

MODULE TO SEPARATE ELECTRIC AND PNEUMATIC SUPPLY HAOM-K

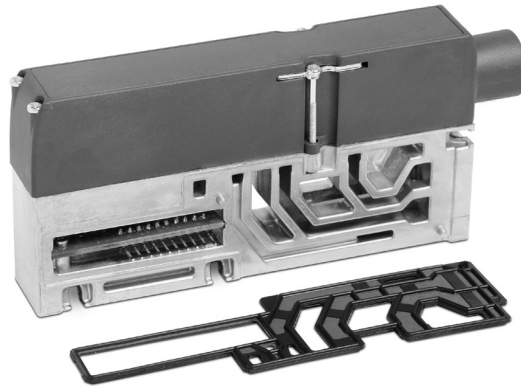

GENERAL DATA	
Connection	3 poles terminal block to be wired
Dimensions	130 x 20 mm
Signalling	None
Supply	24 V DC (+/- 10%)
Electrical protection	Fuse 2 A
Protection class	IP 65
Temperature	0°C ÷ 50°C
Material	Plastics - Aluminium
Weight	100 g

VALVE WITH INTEGRATED PRESSURE REGULATOR HP2V

This solution has the advantage of reducing the valve island's overall height compared to traditional "sandwich" solutions. The pressure regulator allows to set the supply pressure of the lateral valve.

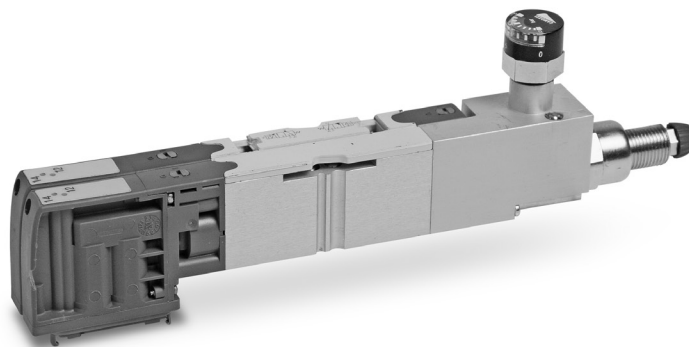

MULTIPOLE version 25 and 37 pin DIMENSIONS

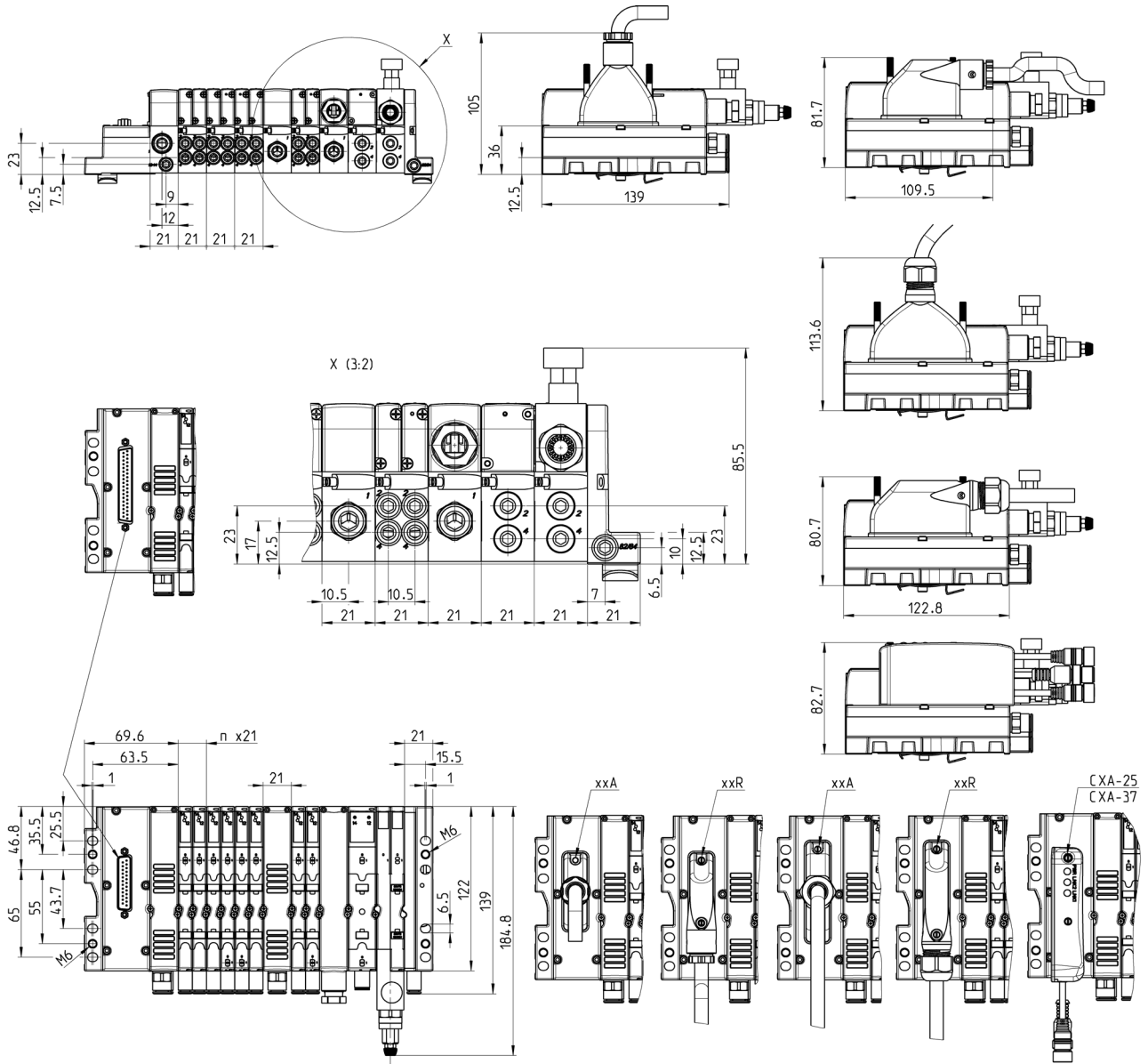

MULTI-SERIAL version DIMENSIONS

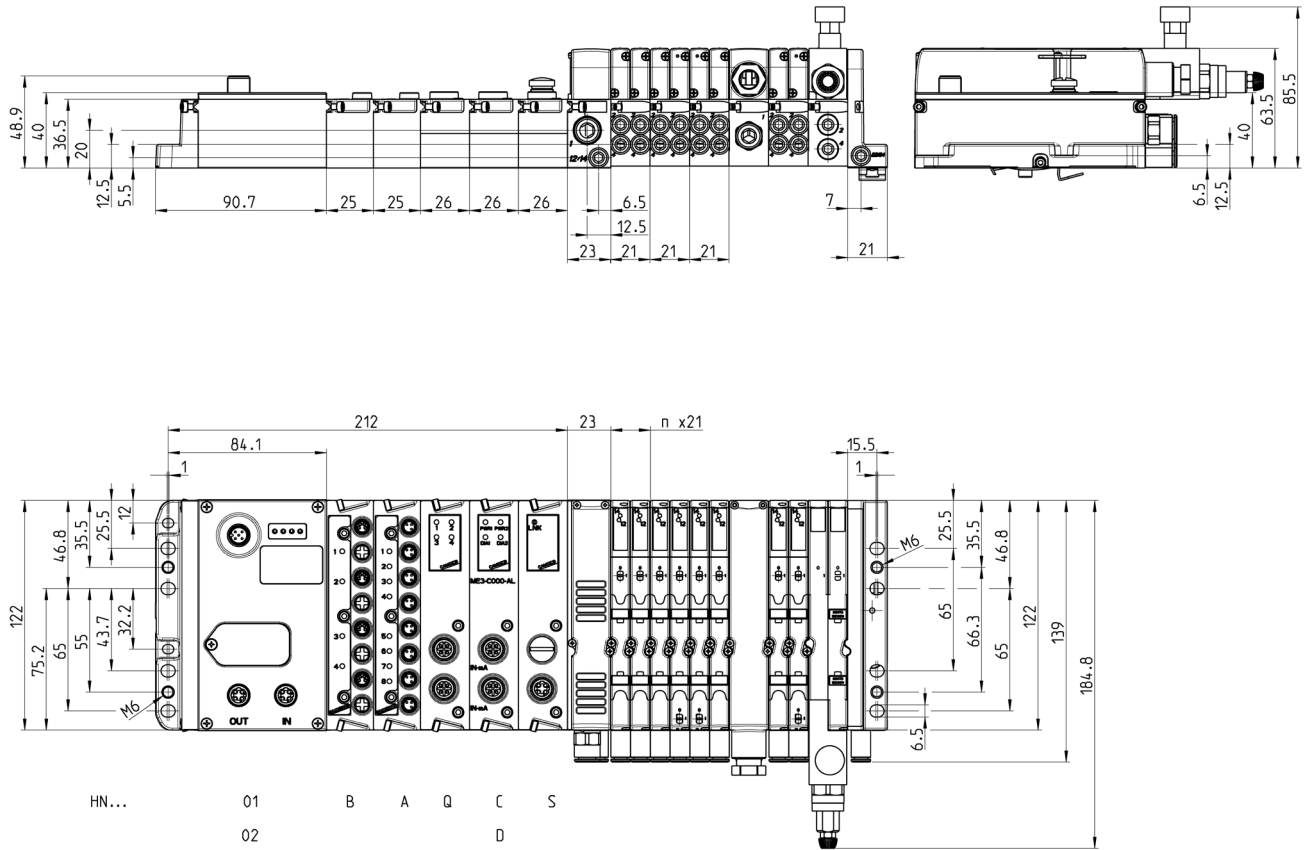

HN...	01	B	A	Q	C	S
	02				D	
	03				E	
	04				R	
	05				T	
	06				U	
					V	
					Z	
					K	
					Y	

SERIES HN VALVE ISLANDS

DIMENSIONS of the EXPANSION MODULE of the multi-serial version

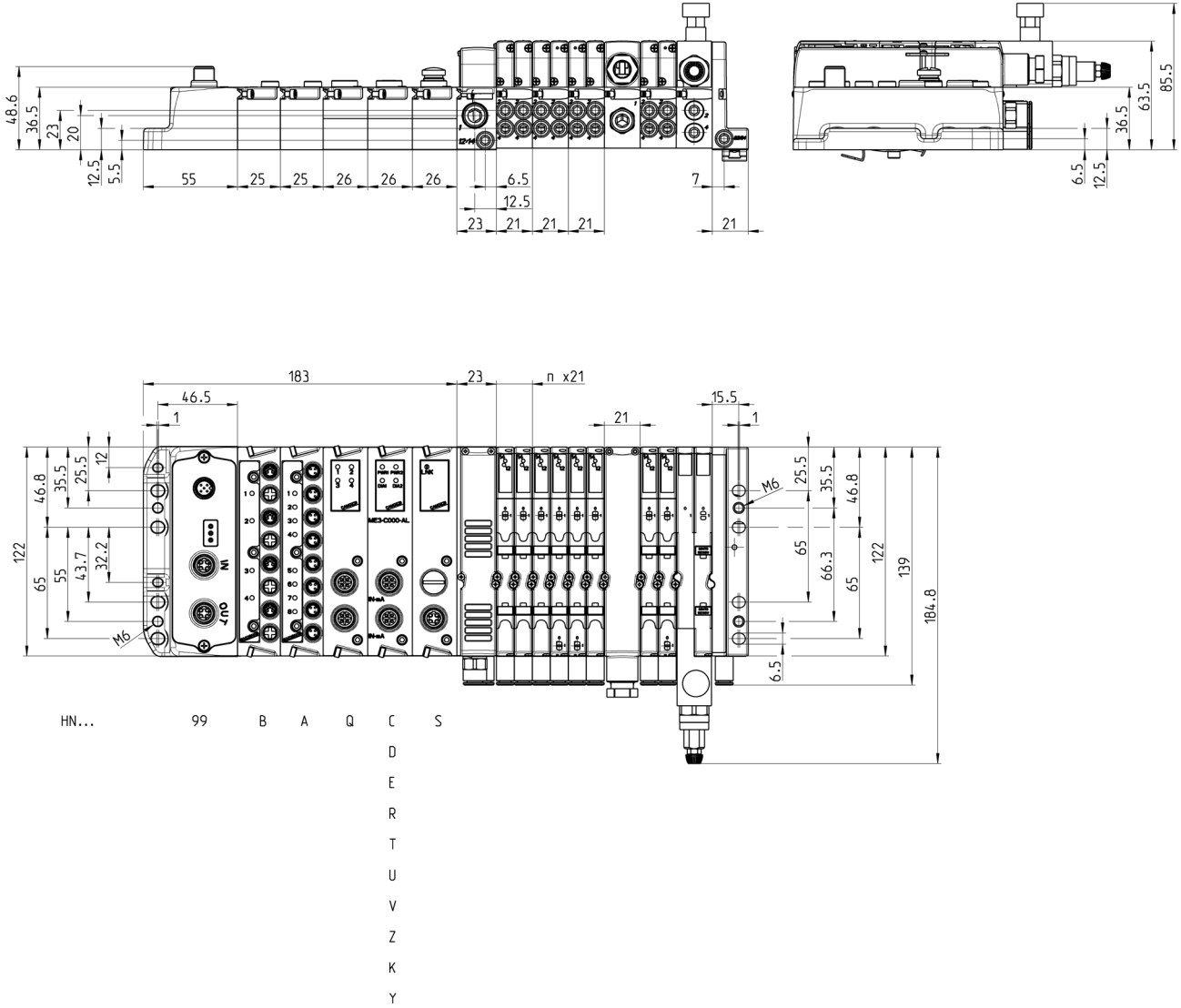

Multi-serial module - pin configuration

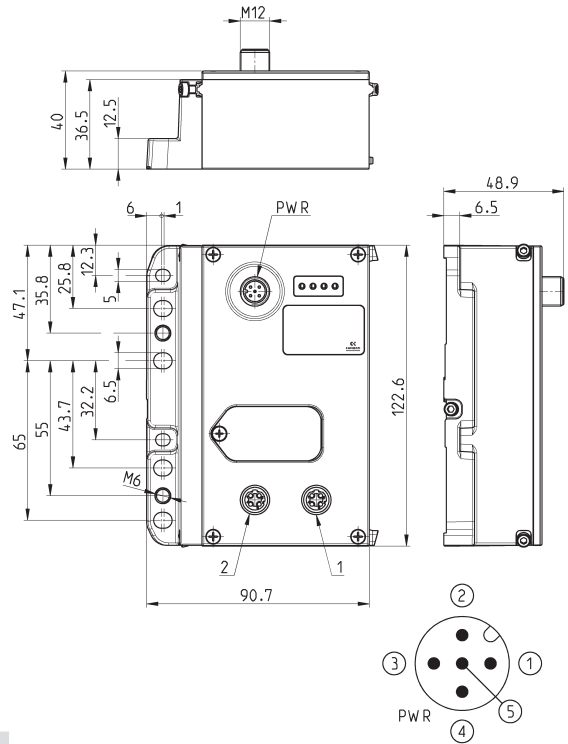

Mod.	Coding reference	Fieldbus Protocol	2	1	Bus-IN connector	Bus-OUT connector
CX01-0-0	01	PROFIBUS	Bus-IN	Bus-OUT	M12 B 5 pin male	M12 B 5 pin female
CX02-0-0	02	DeviceNet	Bus-IN	Bus-OUT	M12 A 5 pin male	M12 A 5 pin female
CX03-0-0	03	CANopen	Bus-IN	Bus-OUT	M12 A 5 pin male	M12 A 5 pin female
CX04-0-0	04	EtherNet/IP	Bus-OUT	Bus-IN	M12 D 5 pin female	M12 D 5 pin female
CX05-0-0	05	EtherCAT	Bus-OUT	Bus-IN	M12 D 5 pin female	M12 D 5 pin female
CX06-0-0	06	PROFINET	Bus-OUT	Bus-IN	M12 D 5 pin female	M12 D 5 pin female

Expansion Module - pin configuration



Note: to connect the Expansion with the subnet, we recommend the use of cables Mod. CS-SB04HB-... or CS-SC04HB-...

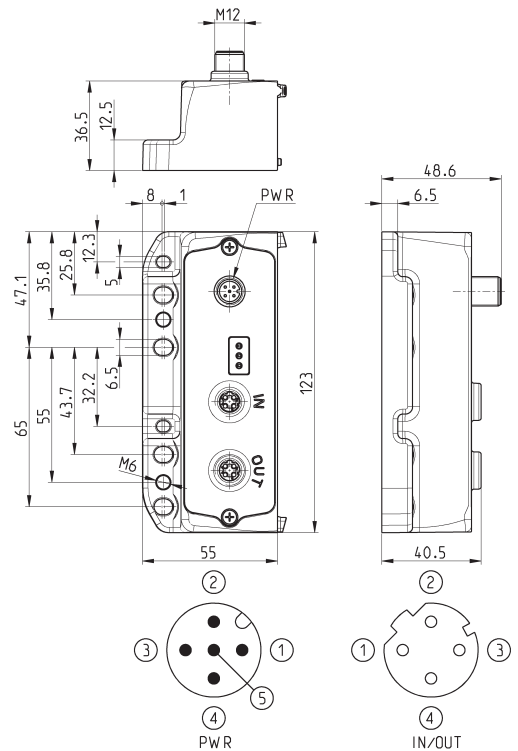

Mod.	Coding reference	Fieldbus Protocol	Bus-IN and Bus-OUT connector
CX99-0-0	99	Subnet expansion	M12 D 5 pin female

Multi-serial module - characteristics

It is a slave node of the main PROFIBUS, CANopen, DeviceNet, EtherNet/IP, EtherCAT, PROFINET network and the Master module of the subnet. All modules provided can be connected only on the right side of the CPU module, like the digital/analog inputs/outputs, direct interface modules for the valve islands (Series F, HN and 3) and the initial module of the subnet. It has its own M12 A 4 pin male connection to supply the modules connected, distinguishing both logic supply and power supply. Two M12 connections for Bus-IN and Bus-OUT of the main network, which M12 connection will take over the relative specifications according to the chosen protocol. The addressing is performed by means of the Rotary Switch for the protocols with this feature, while for Ethernet protocols addressing is performed by means of the protocol itself. Leds indicate the working state. A maximum number of 1024 inputs and 1024 outputs can be managed.

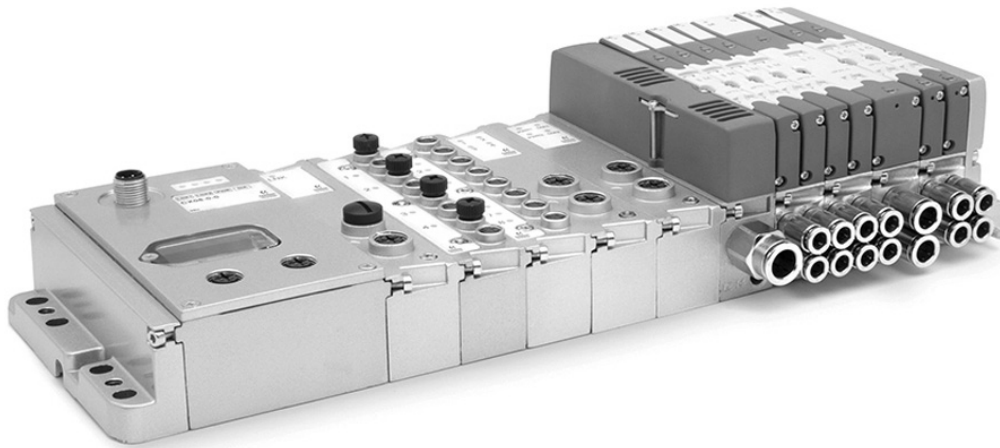

Expansion Module - Characteristics

At its right side, different modules can be connected like the digital/analog inputs/outputs, the direct interface modules for the valve islands (Series F, HN and 3) and the initial module of the subnet to re-amplify it or to create new branches. It has its own M12 A 4 pin male connection to supply the devices connected, distinguishing both logic supply and power supply. It has two M12 D 5 pin female connections for Bus-IN and Bus-OUT connection of the subnet. Leds indicate the working state. The valve island equipped with the Expansion Module can be used only in presence of a subnet.

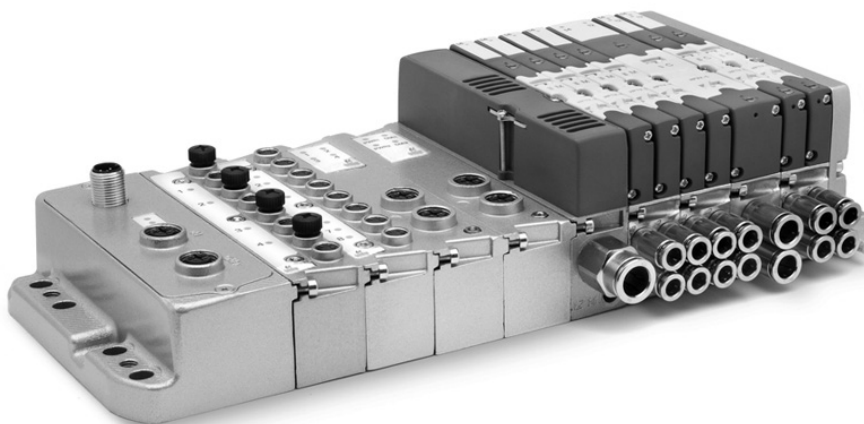

Initial subnet module Mod. ME3-0000-SL

This module can be connected only in presence of a CPU or Expansion module and can be mixed with other either digital or analog Input and Output devices. Every subnet can have an extension of maximum 100 metres, with a maximum of 8 interruptions. Up to maximum 5 initial modules can be connected, one aside another or along the subnet in order to create a tree structure, in series or both, in order to optimize the length of the cables and the topology of the subnet in different applications. The module is equipped with the Bus-OUT connection only of subnet type M12 D 4 pin female.

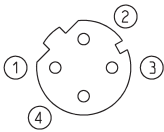

Mod.	Coding reference	Bus-OUT connection	Max number of modules for subnet	Max extension of subnet per module
ME3-0000-SL	S	M12D 4 pin female	5	100 m

Sub-D adaptor module 25 and 37 pin Mod. CXA-25P and CXA-37P



It is an Expansion module of the subnet and can be connected to all valve islands with Sub-D connection. In the 25 pin version, it can manage up to a maximum of 24 outputs, while with 37 pin version, the outputs become 32. It has its own M12 A 4 pin male connection for the supply of the valves connected, distinguishing both logic supply and power supply and two M12 D 4 pin female connections for the Bus-IN and Bus-OUT of the subnet. The subnet can have a length of maximum 100 metres. The power of a single Output is 3 W to 24 V DC. Thanks to the PWM technique it is possible to set a power reduction to only maintain operation.

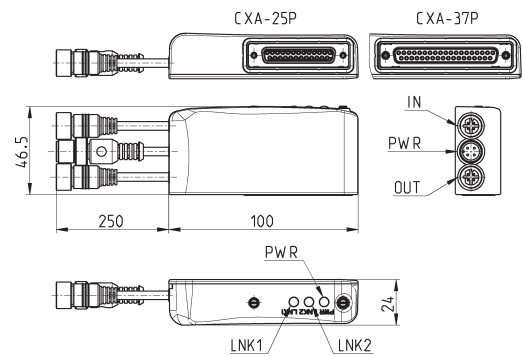

Led 1 = Yellow LNK1
 Led 2 = Yellow LNK2
 Led 3 = Green PWR, supply present and OK

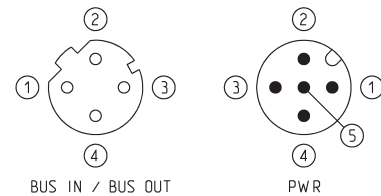

Mod.	Interface	Digital Outs	Bus-IN connection	Bus-OUT connection	PWR connection	Supply	Power for every Output
CXA-25P	Sub-D 25 pin	24	M12D 4 pin female	M12D 4 pin female	M12A 4 pin male	24 V DC	3 W
CXA-37P	Sub-D 37 broches	32	M12D 4 pin female	M12D 4 pin female	M12A 4 pin male	24 V DC	3 W

Digital input Module Mod. ME3-0800-DC and ME3-0400-DC

The Digital input module can be connected only in presence of a CPU or Expansion module and can be mixed with other either digital or analog Input and Output devices and with the initial module of the subnet.
It has 8 or 4 M8 3 pin connections.

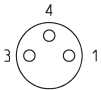

Mod.	Coding reference	Number of digital inputs	Connection	Number of connectors	Dimensions	Signalling	Sensor supply	Overvoltage protection	Absorption	Type of signal	Protection class	Operating temperature	Weight
ME3-0800-DC	A	8	M8 3 pin female	8	122 x 25 mm	1 yellow led for each input	24 V DC	400 mA for 4 sensors	10 mA	PNP	IP65	0 + 50°C	110 g
ME3-0400-DC	B	4	M8 3 pin female	4	122 x 25 mm	1 yellow led for each input	24 V DC	400 mA for 4 sensors	10 mA	PNP	IP65	0 + 50°C	110 g

Analog input/output module Mod. ME3-****-AL

The analog input/output module can be connected only in presence of a CPU or Expansion module and can be mixed with other either digital or analog Input and Output devices and with the initial module of the subnet. It has two M12 A 5 pin female connections and it can be configured as 2 analog Outputs or 2 Inputs or 1 Input + 1 Output. Every analog output has a 12 bit resolution for both inputs and outputs available in the versions from 0-10 V DC and from 4-20mA.
The refreshment time of the analog devices is submitted to the delay of the subnet and therefore to its topology. An average delay is less than 6 ms, to which the delay of the main network managed by the PLC has to be added.

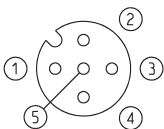

Mod.	Coding reference	Number of analog inputs	Number of analog outputs	Connection
ME3-C000-AL	C	2 inputs 4-20 mA	-	2x M12 A 5 pin female
ME3-D000-AL	D	2 inputs 0-10 V	-	2x M12 A 5 pin female
ME3-E000-AL	E	1 input 4-20 mA + 1 input 0-10 V	-	2x M12 A 5 pin female
ME3-00U0-AL	U	-	1 output 4-20 mA + 1 output 0-10 V	2x M12 A 5 pin female
ME3-00R0-AL	R	-	2 outputs 4-20 mA	2x M12 A 5 pin female
ME3-00T0-AL	T	-	2 outputs 0-10 V	2x M12 A 5 pin female
ME3-00Z0-AL	Z	1 input 4-20 mA	1 output 4-20 mA	2x M12 A 5 pin female
ME3-00K0-AL	K	1 input 0-10 V	1 output 0-10 V	2x M12 A 5 pin female
ME3-00V0-AL	V	1 input 0-10 V	1 output 4-20 mA	2x M12 A 5 pin female
ME3-00Y0-AL	Y	1 input 4-20 mA	1 output 0-10 V	2x M12 A 5 pin female

Digital power output module Mod. ME3-0004-DL

The digital output module can be connected only in presence of a CPU or Expansion module and can be mixed with other either digital or analog Input and Output devices and with the initial module of the subnet. It has two M12 A 5 pin female connections, each connection can manage 2 digital outputs and can provide a maximum of 10 W to 24 V DC. The device is useful to pilot a bistable valve or two monostable valves for each connector, or to activate the electric coils or other electric devices with maximum absorption of 10 W to 24 V DC. Connecting two outputs to one electric device only and activating them simultaneously, it is possible to provide maximum 20 W to 24 V DC.

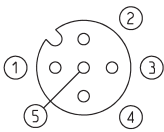

Mod.	Coding reference	Number of digital outputs	Connection	Number of connectors	Dimensions	Signalling	Sensor supply	Max power for M12 connector	Max power for digital output	Type of signal	Protection class	Operating temperature	Weight
ME3-0004-DL	Q	4	M12 A 5 pin female	2	122 x 25 mm	1 yellow led for each output	24 V DC	20 W	10 W	NPN	IP65	0 ÷ 50°C	100 g

Adaptor and panel mount for Ethernet RJ45 to M12 D networks

For PROFINET, EtherCAT, EtherNet/IP

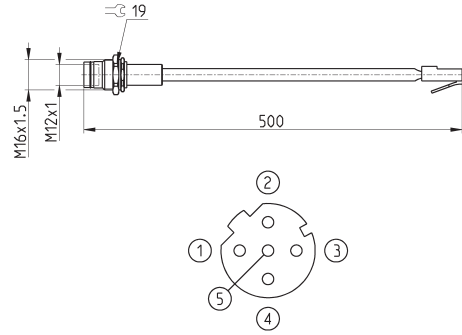

Mod.	description	type of connector	connection	cable length (m)
CS-SE04HB-F050	moulded cable	straight	RJ45 male, M12 D 4 pin female - Pin 5 is not connected	0.5

Profibus-DP data line tee

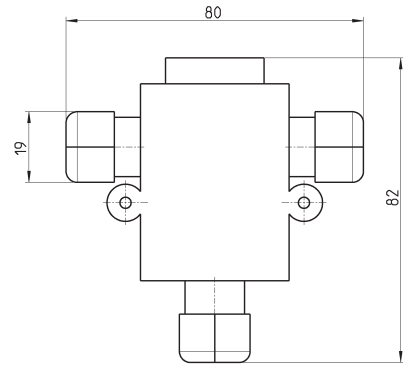

Mod.
CS-AA03EC

CANopen / DeviceNet data line tee

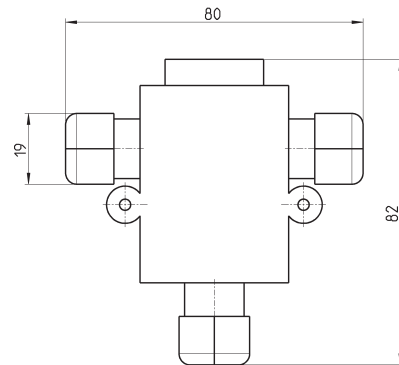

Mod.
CS-AA05EC

M12 male terminating resistor

For PROFIBUS, CANopen, DeviceNet

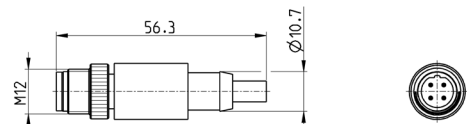

Mod.	description	type of connector	connection	Protocol
CS-MQ05H0	moulded terminating resistor	straight	M12 B 4 pin male - Pin 5 is not connected	PROFIBUS
CS-LP05H0	moulded terminating resistor	straight	M12 A 5 pin male - Pin 5 is connected	CANopen / DeviceNet

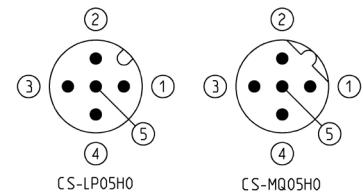

Subnet terminating resistor

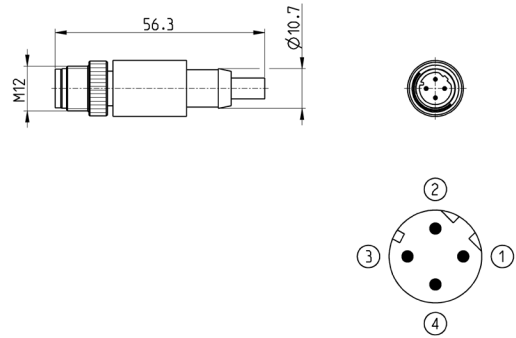

Mod.	description	type of connector	connection	Protocol
CS-SU04H0	moulded terminating resistor	straight	M12 D 4 pin	subnet

Straight connector for power supply

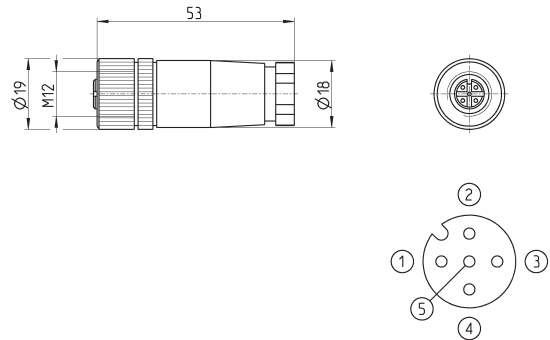

Mod.	description	type of connector	connection	cable length (m)
CS-LF04HB	for wiring	straight	M12 A 4 pin female - Pin 5 is not connected	-

Angular connector for power supply

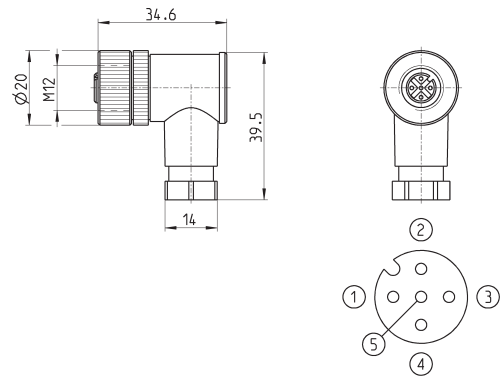

Mod.	description	type of connector	connection	cable length (m)
CS-LR04HB	for wiring	90°	M12 A 4 pin female - Pin 5 is not connected	-

Straight female M12 connectors for Bus-IN

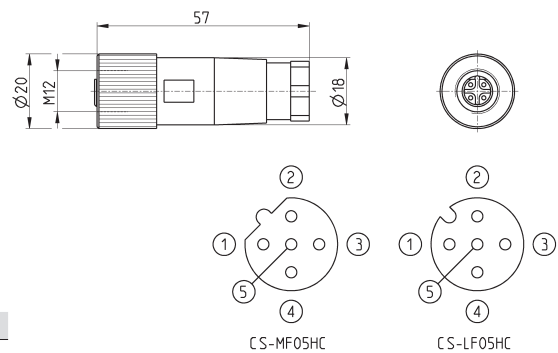

Mod.	description	type of connector	connection	Protocol
CS-LF05HC	for wiring	straight	M12 A 5 pin female	CANopen / DeviceNet
CS-MF05HC	for wiring	straight	M12 B 5 pin female	PROFIBUS

Angular 90° female M12 connectors for Bus-IN

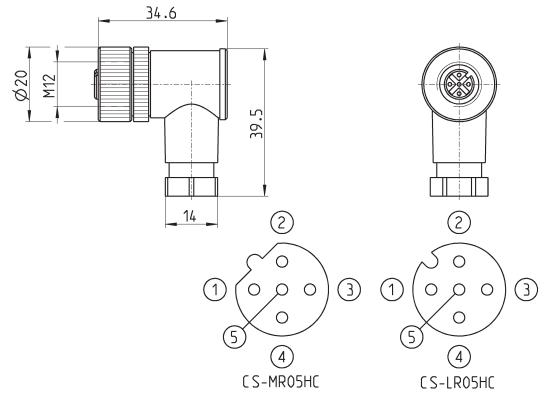

Mod.	description	type of connector	connection	Protocol
CS-LR05HC	for wiring	90°	M12 A 5 pin female	CANopen / DeviceNet
CS-MR05HC	for wiring	90°	M12 B 5 pin female	PROFIBUS

Straight male M12 connectors for Bus-OUT

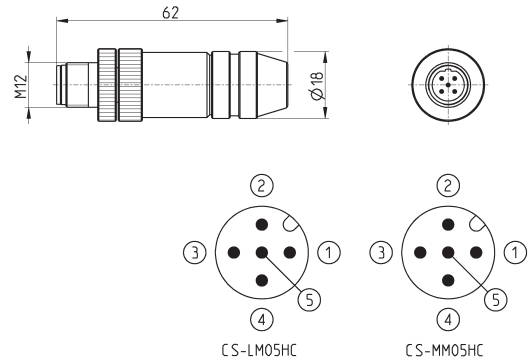

Mod.	description	type of connector	connection	Protocol
CS-LM05HC	for metal wiring	straight	M12 A 5 pin male	CANopen / DeviceNet
CS-MM05HC	for metal wiring	straight	M12 B 5 pin male	PROFIBUS

Angular 90° male M12 connectors for Bus-OUT



The Mod. CS-LS05HC can also be used for the connection of the digital output modules and of the analog input and output modules.

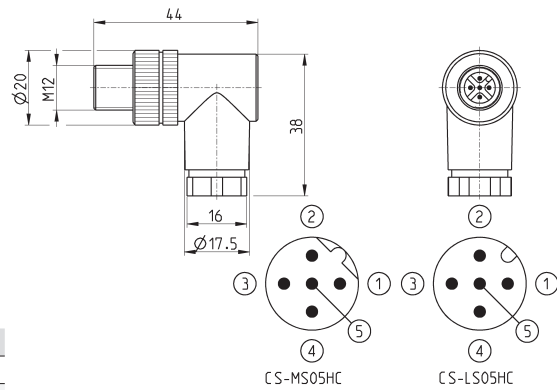

Mod.	description	type of connector	connection	Protocol
CS-LS05HC	for wiring	90°	M12 A 5 pin male	CANopen / DeviceNet
CS-MS05HC	for wiring	90°	M12 B 5 pin male	PROFIBUS

5 pin male straight M12 DUO connector



For the connection of the digital output modules and analog input/output modules.

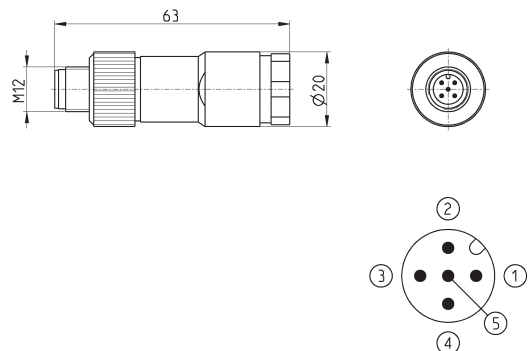

Mod.	description	type of connector	connection	cable length (m)
CS-LD05HF	for wiring	straight	M12 A 5 pin male	-

5 pin male angular M12 DUO connector



For the connection of the digital output modules ME3-0004-DL

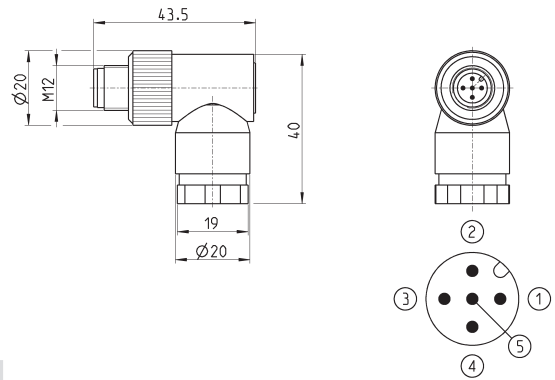

Mod.	description	type of connector	connection	cable length (m)
CS-LH05HF	for wiring	90°	M12 A 5 pin male	-

3 pin male M8 wiring connector for digital input modules

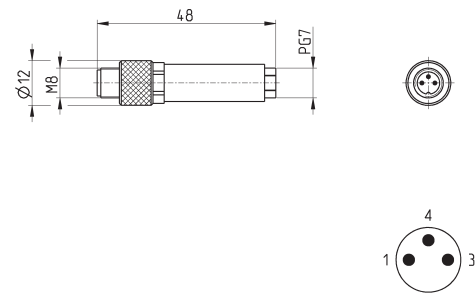

Mod.	description	type of connector	connection	cable length (m)
CS-DM03HB	for wiring	straight	M8 3 pin male	-

Male wiring connector for Bus-IN and Bus-OUT



For PROFINET, EtherCAT, EtherNet/IP and for the subnet

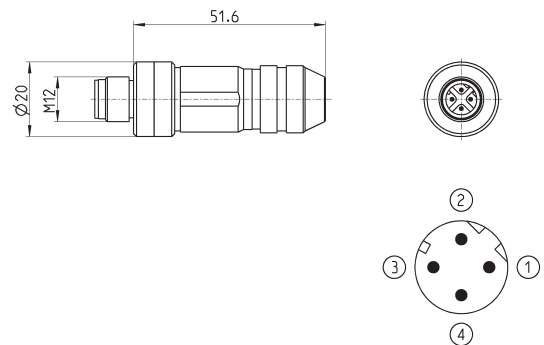

Mod.	description	type of connector	connection	cable length (m)
CS-SM04HO	for metal wiring	straight	M12 D 4 pin	-

Extension with M8 connector, 3 pin male / female

Non shielded



For the connection of the digital input modules ME3-0008 and ME3-0004

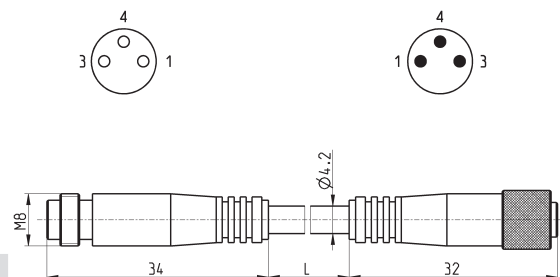

Mod.	description	type of connector	connection	L [cable length] (m)
CS-DW03HB-C250	moulded cable	straight	M8 3 pin male / female	2.5
CS-DW03HB-C500	moulded cable	straight	M8 3 pin male / female	5

USB to Micro USB cable Mod. G11W-G12W-2

For the hardware configuration of the Camozzi products

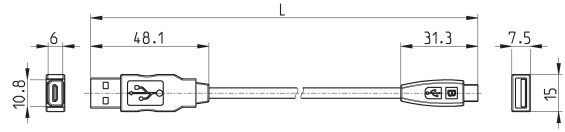

Mod.	description	connections	material for outer sheath	cable length "L" (m)
G11W-G12W-2	black shielded cable 28 AWG	standard USB to Micro USB	PVC	2

Adapter cable, M8 3-pin male - M12 4-pin female

Protection class: IP69K

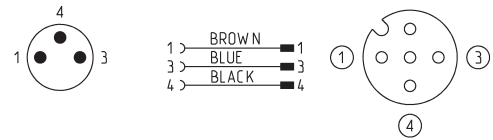
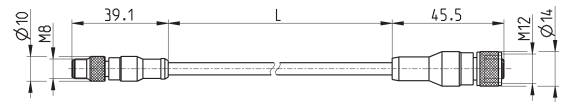

Mod.	description	max voltage	max current	Nr conn. wires	connections	outer sheath	cable "L" (m)
CS-AG03HB-C250	3-pin cable 24 AWG, high flexibility	50V AC / 60V DC	3 A	3	M8 3-pin male - M12 4-pin fem.	PUR black	2.5
CS-AG03HB-C500	3-pin cable 24 AWG, high flexibility	50V AC / 60V DC	3 A	3	M8 3-pin male - M12 4-pin fem.	PUR black	5

Straight Sub-D 25 pin female connector with axial cable

Protection class IP65

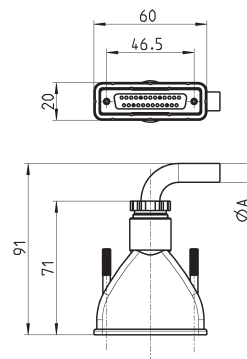

Mod.	øA	PIN	cable length (m)
G3X-3	7.7	16	3
G3X-5	7.7	16	5
G3X-10	7.7	16	10
G3X-15	7.7	16	15
G3X-20	7.7	16	20
G3X-25	7.7	16	25
G4X-3	9	25	3
G4X-5	9	25	5
G4X-10	9	25	10
G4X-15	9	25	15
G4X-20	9	25	20
G4X-25	9	25	25

Right angle Sub-D 25 pin female connector with radial cable

Protection class IP65

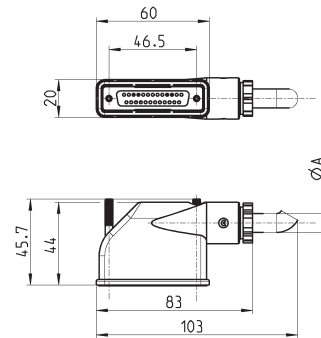

Mod.	$\varnothing A$	PIN	cable length (m)
G3X1-3	7.7	16	3
G3X1-5	7.7	16	5
G3X1-10	7.7	16	10
G3X1-15	7.7	16	15
G3X1-20	7.7	16	20
G3X1-25	7.7	16	25
G4X1-3	10	25	3
G4X1-5	10	25	5
G4X1-10	10	25	10
G4X1-15	10	25	15
G4X1-20	10	25	20
G4X1-25	10	25	25

Straight Sub-D 37 pin female connector with axial cable

Protection class IP65

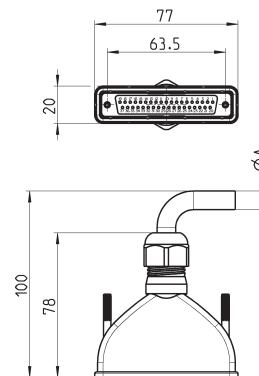

Mod.	$\varnothing A$	PIN	cable length (m)
G9X-3	12	37	3
G9X-5	12	37	5
G9X-10	12	37	10
G9X-15	12	37	15
G9X-20	12	37	20
G9X-25	12	37	25

Right angle Sub-D 37 pin female connector with radial cable

Protection class IP65

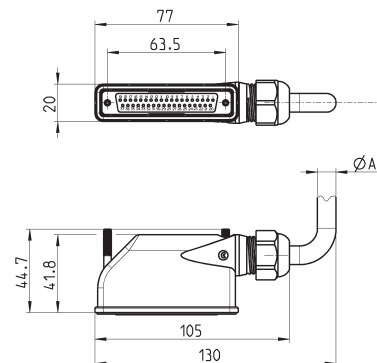

Mod.	$\varnothing A$	PIN	cable length (m)
G9X1-3	12	37	3
G9X1-5	12	37	5
G9X1-10	12	37	10
G9X1-15	12	37	15
G9X1-20	12	37	20
G9X1-25	12	37	25

Cables with straight connectors



For PROFINET, EtherCAT, EtherNet/IP and for the subnet

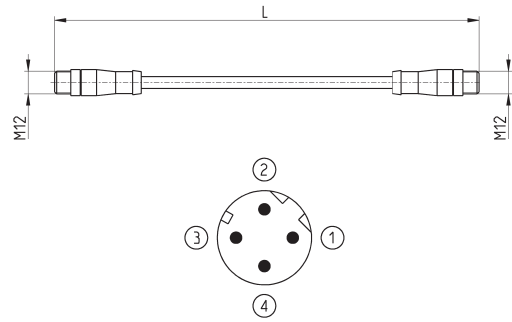

Mod.	description	type of connector	connection	L [cable length] (m)
CS-SB04HB-D100	moulded cable	straight	2x M12 D 4 pin male	1
CS-SB04HB-D500	moulded cable	straight	2x M12 D 4 pin male	5
CS-SB04HB-DA00	moulded cable	straight	2x M12 D 4 pin male	10
CS-SB04HB-DD00	moulded cable	straight	2x M12 D 4 pin male	15
CS-SB04HB-DG00	moulded cable	straight	2x M12 D 4 pin male	20
CS-SB04HB-DJ00	moulded cable	straight	2x M12 D 4 pin male	25

Cables with 90° angular connectors



For PROFINET, EtherCAT, EtherNet/IP and for the subnet

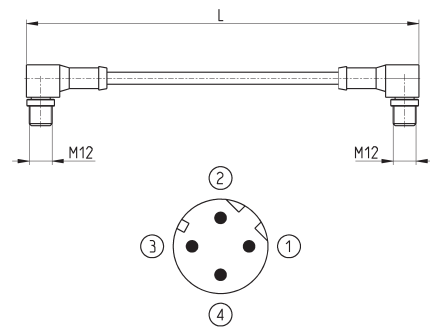

Mod.	description	type of connector	connection	L [cable length] (m)
CS-SC04HB-D100	moulded cable	90°	2x M12 D 4 pin male	1
CS-SC04HB-D500	moulded cable	90°	2x M12 D 4 pin male	5
CS-SC04HB-DA00	moulded cable	90°	2x M12 D 4 pin male	10
CS-SC04HB-DD00	moulded cable	90°	2x M12 D 4 pin male	15
CS-SC04HB-DG00	moulded cable	90°	2x M12 D 4 pin male	20
CS-SC04HB-DJ00	moulded cable	90°	2x M12 D 4 pin male	25

M8 and M12 connector cover caps



For digital and analog input/output modules and subnet

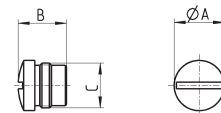

Mod.	A	B	C [Connection]
CS-DFTP	10	11	M8
CS-LFTP	13.5	13	M12

Mounting brackets for DIN rail



DIN EN 50022 (mm 7,5 x 35 - width 1)

Supplied with:
2x plates
2x screws M4x6 UNI 5931

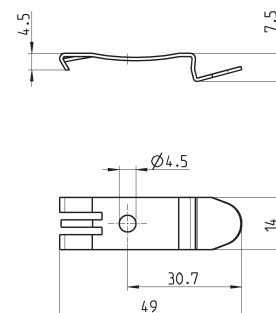

Mod.
PCF-E520

CODING EXAMPLE OF MULTIPOLE AND FIELDBUS INTERFACES - Accessories

HN	A	0	M	-	A
HN	SERIES				
A	TYPE: A = Accessory				
0	SIZE: 0 = not defined				
M	ELECTRICAL CONNECTION: M = 25 pin PNP Multipole N = 25 pin NPN Multipole H = 37 pin PNP Multipole L = 37 pin NPN Multipole I = HN interface with Series CX				
A	TERMINALS: A = 1, 12/14 in common - 3/5, 82/84 with thread B = 1, 12/14 separated - 3/5, 82/84 with thread C = 1, 12/14 in common - 3/5, 82/84 with silencer D = 1, 12/14 separated - 3/5, 82/84 with silencer NOTE: The Right Terminal is supplied with seals and fixing screws and available as accessory with the commercial code HA0T-H				

Detailed descriptions of the available accessories can be found in the components list on page 1.40.08 (Multipole version) e 1.40.09 (Fieldbus version)

CODING EXAMPLE OF SINGLE VALVE (Spare part)

H	P	1	V	-	M		
H	SERIES						
P	TYPE: P = pneumatic						
1	SIZE: 1 = 10.5 2 = 21						
V	TYPE OF ACCESSORY: V = Solenoid valve						
M	<table border="0"> <tr> <td>SOLENOID VALVE: M = 5/2 Monostable B = 5/2 Bistable V = 5/3 Centres Closed C = 2 x 3/2 NC A = 2 x 3/2 NO G = 1 x 3/2 NC + 1 x 3/2 NO E = 2 x 2/2 NC F = 2 x 2/2 NO I = 1 x 2/2 NC + 1 x 2/2 NO L = free position</td> <td>SOLENOID VALVE + REGULATOR + SUBBASE N = 5/2 Monostable P = 5/2 Bistable Q = 5/3 Centres Closed R = 2 x 3/2 NC S = 2 x 3/2 NO T = 1 x 3/2 NC + 1 x 3/2 NO U = 2 x 2/2 NC X = 2 x 2/2 NO Y = 1 x 2/2 NC + 1 x 2/2 NO</td> </tr> </table>					SOLENOID VALVE: M = 5/2 Monostable B = 5/2 Bistable V = 5/3 Centres Closed C = 2 x 3/2 NC A = 2 x 3/2 NO G = 1 x 3/2 NC + 1 x 3/2 NO E = 2 x 2/2 NC F = 2 x 2/2 NO I = 1 x 2/2 NC + 1 x 2/2 NO L = free position	SOLENOID VALVE + REGULATOR + SUBBASE N = 5/2 Monostable P = 5/2 Bistable Q = 5/3 Centres Closed R = 2 x 3/2 NC S = 2 x 3/2 NO T = 1 x 3/2 NC + 1 x 3/2 NO U = 2 x 2/2 NC X = 2 x 2/2 NO Y = 1 x 2/2 NC + 1 x 2/2 NO
SOLENOID VALVE: M = 5/2 Monostable B = 5/2 Bistable V = 5/3 Centres Closed C = 2 x 3/2 NC A = 2 x 3/2 NO G = 1 x 3/2 NC + 1 x 3/2 NO E = 2 x 2/2 NC F = 2 x 2/2 NO I = 1 x 2/2 NC + 1 x 2/2 NO L = free position	SOLENOID VALVE + REGULATOR + SUBBASE N = 5/2 Monostable P = 5/2 Bistable Q = 5/3 Centres Closed R = 2 x 3/2 NC S = 2 x 3/2 NO T = 1 x 3/2 NC + 1 x 3/2 NO U = 2 x 2/2 NC X = 2 x 2/2 NO Y = 1 x 2/2 NC + 1 x 2/2 NO						

Detailed descriptions of the available accessories can be found in the components list on page 1.40.08 (Multipole version) e 1.40.09 (Fieldbus version)

CODING EXAMPLE OF SUBBASES - Accessories

H	A	1	R	-	A
----------	----------	----------	----------	---	----------

H	SERIES		
A	TYPE: A = accessories		
1	SIZE: 0 = for X-Y-K-T-U-V-Z 1 = 10.5 2 = Z1		
S	TYPE OF ACCESSORY: R = subbase for multipole connection G = seal W = subbase without electronic board (option valid only for position 2a. See the components list on page 1.40.08 - Multipole version - and 1.40.09 - Fieldbus version)		
A	<table border="0" style="width: 100%;"> <tr> <td style="vertical-align: top;"> <p>SUBBASE:</p> <p>A = through - M7 threads AZ = through - M7 threads, monostable D = channel 1, 3, 5 closed - M7 threads DZ = channel 1, 3, 5 closed - M7 threads, monostable G = channel 3, 5 closed - M7 threads GZ = channel 3, 5 closed - M7 threads, monostable P = through - G1/4 threads Q = through - G1/8 threads X = supplementary supply and exhaust Y = supplementary supply and exhaust with integrated silencer W = supply from the exhausts K = separation of electrical supply and supplementary pneumatic supply</p> </td> <td style="vertical-align: top;"> <p>SEAL:</p> <p>T = diaphragm seal for the closure of channels 1, 3, 5 U = diaphragm seal for the closure of channel 1 V = diaphragm seal for the closure of channels 3, 5 P = through</p> </td> </tr> </table>	<p>SUBBASE:</p> <p>A = through - M7 threads AZ = through - M7 threads, monostable D = channel 1, 3, 5 closed - M7 threads DZ = channel 1, 3, 5 closed - M7 threads, monostable G = channel 3, 5 closed - M7 threads GZ = channel 3, 5 closed - M7 threads, monostable P = through - G1/4 threads Q = through - G1/8 threads X = supplementary supply and exhaust Y = supplementary supply and exhaust with integrated silencer W = supply from the exhausts K = separation of electrical supply and supplementary pneumatic supply</p>	<p>SEAL:</p> <p>T = diaphragm seal for the closure of channels 1, 3, 5 U = diaphragm seal for the closure of channel 1 V = diaphragm seal for the closure of channels 3, 5 P = through</p>
<p>SUBBASE:</p> <p>A = through - M7 threads AZ = through - M7 threads, monostable D = channel 1, 3, 5 closed - M7 threads DZ = channel 1, 3, 5 closed - M7 threads, monostable G = channel 3, 5 closed - M7 threads GZ = channel 3, 5 closed - M7 threads, monostable P = through - G1/4 threads Q = through - G1/8 threads X = supplementary supply and exhaust Y = supplementary supply and exhaust with integrated silencer W = supply from the exhausts K = separation of electrical supply and supplementary pneumatic supply</p>	<p>SEAL:</p> <p>T = diaphragm seal for the closure of channels 1, 3, 5 U = diaphragm seal for the closure of channel 1 V = diaphragm seal for the closure of channels 3, 5 P = through</p>		

Detailed descriptions of the available accessories can be found in the components list on page 1.40.08 (Multipole version) e 1.40.09 (Fieldbus version)
NOTE: subbases are always supplied without connection fittings.